

RD139

AAM 11.5" Rear

PARTS LIST

ITEM #	QTY	DESCRIPTION	PART #	NOTES
01	1	FLANGE CAP KIT	028603SP	
02	1	BONDED SEAL	160703SP	
03	1	CLUTCH GEAR & WAVESPRING KIT	050907SP	5
*	1	CLUTCH GEAR & RETURN SPRINGS KIT	050807SP	5
04	1	SPIDER BLOCK	070402SP	
05	1	LONG CROSS SHAFT	061501SP	
06	4	PINION GEAR	SEE NOTE	2
07	4	PINION THRUST WASHER	SEE NOTE	3
08	1	SIDE GEAR	SEE NOTE	2
09	2	SIDE GEAR THRUST WASHER	SEE NOTE	3
10	1	DIFFERENTIAL CASE (SUITS WAVESPRING ONLY)	013223SP	4
*	1	DIFFERENTIAL CASE (SUITS RETURN SPRINGS ONLY)	013203SP	4
11	1	COUNTERSUNK SCREW (PK OF 2)	200214SP	
12	1	RETAINING PIN SET (PK OF 4)	120601SP	
13	-	TAPERED ROLLER BEARING	NOT SUPPLIED	
14	1	SEAL HOUSING O-RINGS (PK OF 2)	160246-2	
15	1	SEAL HOUSING BRACKET	220209	
16	1	SEAL HOUSING KIT	082102SP	1
17	1	WAVESPRING	150707SP	5
*	1	RETURN SPRINGS KIT	150107SP	5
18	1	SPLINED SIDE GEAR	SEE NOTE	2
19	2	SHORT CROSS SHAFT	061601SP	
*	1	SEAL HOUSING BRACKET	220209	
*	1	BULKHEAD FITTING KIT (BANJO TYPE)	170114	6
*	1	AIR LINE (6mm DIA X 6m LONG)	170314	6
*	1	SOLENOID VALVE (12V)	180103	
*	1	SWITCH RR LOCKER	180224	
*	1	CABLE TIE (PK OF 25)	180305	
*	1	OPERATING & SERVICE MANUAL	210200	
*	1	INSTALLATION GUIDE	2102139	

* *Not illustrated in exploded view*

NOTES

- 1 For replacement O-rings use only BS151 Viton 75.
- 2 Available only as complete 6 gear set # 728K011.
- 3 Available only as complete thrust washer kit #730K01.
- 4 Identify the spring type in your diff and order the correct diff case to replace.
- 5 Replace the spring and/or the corresponding clutch gear with the same type.
(If spring type is changed, a matching diff case must also be used. See item 10.)
- 6 All diffs produced before serial #17070001 came with 5mm air connection system. For information contact ARB.

RD139

AAM 11.5" Rear

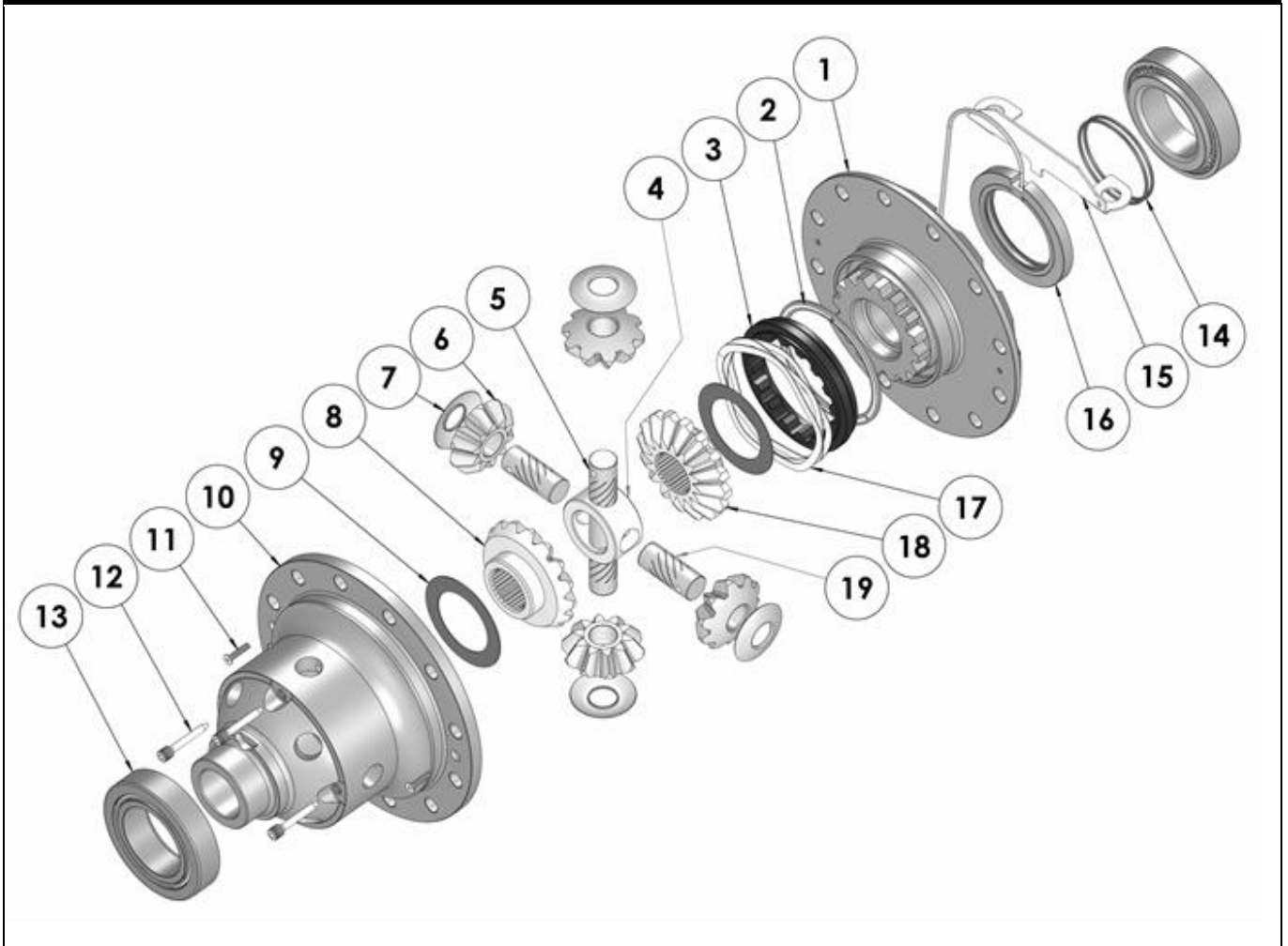
EXPLODED DIAGRAM**SPECIFICATIONS**

Axle Spline	30 tooth, Ø39.1mm [1.54"]
Ratio Supported	All
Ring Gear ID	187.2mm [7.37"]
Ring Gear OD	292.1mm [11.5"]
Ring Gear Bolts	12 bolts on Ø220.0mm [8.66"]
Ring Gear Torque	237Nm [175 ft-lb]
Backlash	0.12-0.18mm [0.003-0.005"]
Bearing Cap Torque	280Nm [207 ft-lb]

ARB Corporation Ltd • 42-44 Garden St Kilsyth VIC 3137 Australia
ARB 4X4 Accessories USA • 720 SW 34th St Renton WA 98057 USA
Australia & International Customer Service • +61 3 9761 6622
North America Customer Service • Toll Free 866 293 9078
www.arb.com.au (AUS & Int) www.arbusa.com (N. America)

