

RD141

Toyota 8" IFS,34 SPL,58mm BRNG

****THIS MODEL WAS SUPERSEDED BY RD151, CROSSED OUT PARTS NOT AVAILABLE**

PARTS LIST

ITEM #	QTY	DESCRIPTION	PART #	NOTES
01	1	BONDED SEAL	160703SP	
02	1	CLUTCH GEAR & WAVESPRING KIT	050904SP	4
03	1	WAVESPRING	150704SP	
04	1	LONG CROSS SHAFT	060204SP	
05	1	SPIDER BLOCK	070201SP	
06	1	DIFFERENTIAL CASE	013022SP	
07	1	RETAINING PIN SET (PK OF 4)	120601SP	
08	---	TAPERED ROLLER BEARING	NOT SUPPLIED	
09	1	SHIM KIT	SHK009	
*	1	MASTER SHIM	150305	
10	1	SEAL HOUSING KIT	081812SP	
11	1	SEAL HOUSING O-RINGS (PK OF 2)	160207-2	1
12	1	FLANGE CAP KIT	027322SP	
13	1	LOCKING SIDE GEAR	SEE NOTE	2
14	4	PINION THRUST WASHER	SEE NOTE	3
15	4	PINION GEAR	SEE NOTE	2
16	2	SHORT CROSS SHAFT	060403SP	
17	1	SIDE GEAR	SEE NOTE	2
18	2	SIDE GEAR THRUST WASHER	SEE NOTE	3
19	1	COUNTERSUNK SCREW (PK OF 2)	200213SP	
20	2	ANTI-FRICTION BUSHING (PTFE)	160805SP	
*	1	BULKHEAD FITTING KIT (BANJO TYPE)	170114	5
*	1	NYLON AIR LINE (6mm DIA X 6m LONG)	170314	5
*	1	SOLENOID VALVE (12V)	180103	
*	1	SWITCH FR LOCKER	180223	
*	1	CABLE TIE (PK OF 25)	180305	
*	1	OPERATING & SERVICE MANUAL	210200	
*	1	INSTALLATION GUIDE	2102141	

* *Not illustrated in exploded view*

NOTES

- 1 For replacement O-rings use only BS136 Viton 75.
- 2 Available only as complete 6 gear set #728H191
- 3 Available only as complete thrust washer kit #730H01
- 4 Always bench test both engagement and disengagement of the clutch gear before reinstalling *Air Locker* into the vehicle.
- 5 All diffs produced before serial #17070001 came with 5mm air connection system. For information contact ARB.
- Spare axle retaining clips may be required (not supplied) to refit CV shafts.
- For 8" IFS with 50mm carrier bearings refer to RD131 ([Section 2.131](#)).
- For 8" IFS with 53mm carrier bearings refer to RD111 ([Section 2.111](#)) or RD121 ([Section 2.121](#)).

RD141

Toyota 8" IFS, 34 SPL, 58mm BRNG

****THIS MODEL WAS SUPERSEDED BY RD151, CROSSED OUT PARTS NOT AVAILABLE**

EXPLODED DIAGRAM

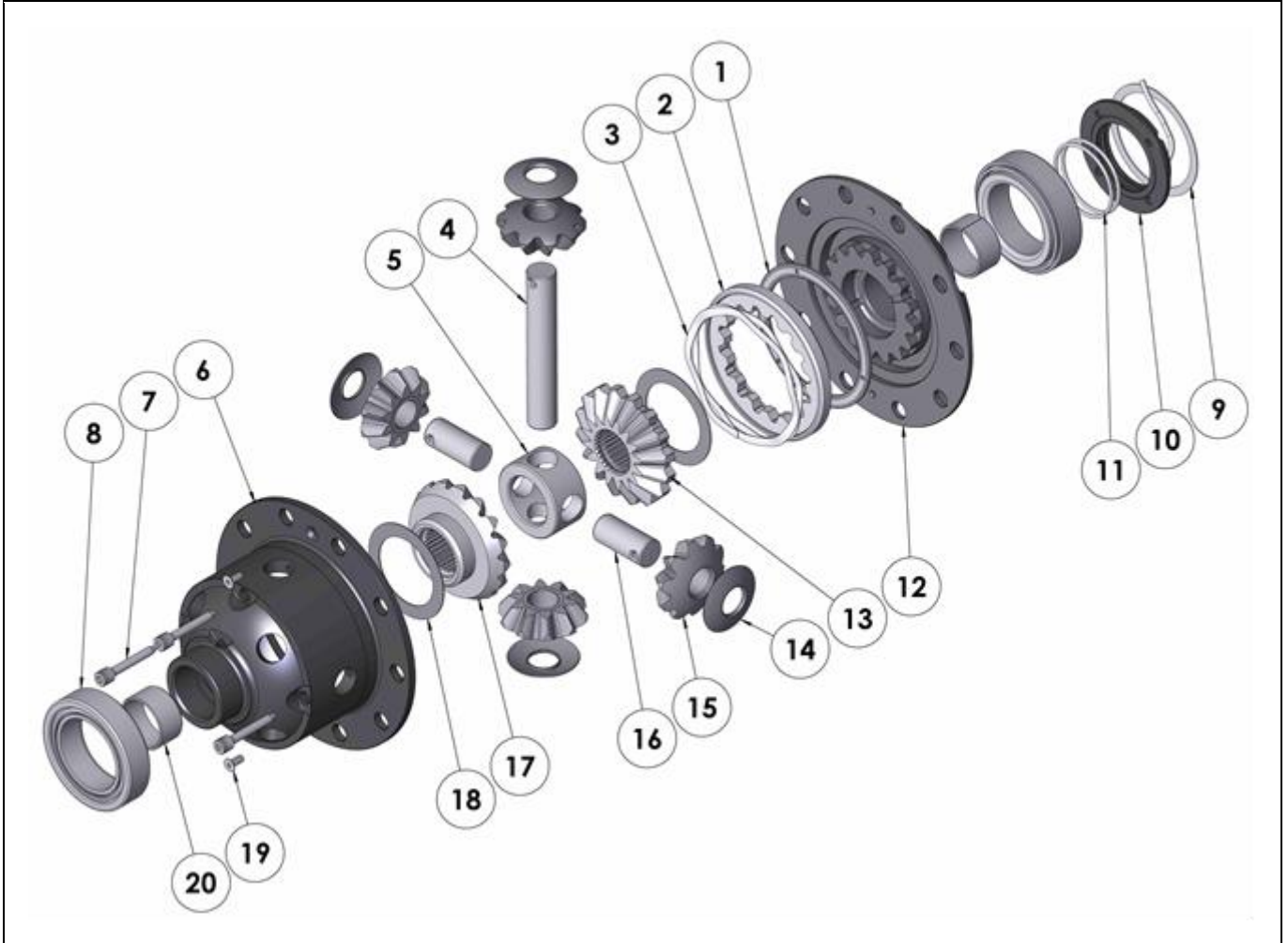

SPECIFICATIONS

Axle Spline	34 tooth, Ø34.9mm [1.37"]
Ratio Supported	All
Ring Gear ID	134.0mm [5.28"]
Ring Gear OD	200mm [8"]
Ring Gear Bolts	12 bolts on Ø160mm [6.30"]
Ring Gear Torque	135Nm [100 ft-lb]
Backlash	0.15-0.25mm [0.006-0.010"]