

RD25

Mitsubishi 9",RR,28 SPL,disc brake**

****THIS MODEL WAS SUPERSEDED BY RD212, CROSSED OUT PARTS NOT AVAILABLE**

PARTS LIST

| ITEM # | QTY | DESCRIPTION | PART # | NOTES |
|--------|-----|------------------------------------|--------------|-------|
| 01 | 1 | FLANGE CAP | 021202 | |
| 02 | 1 | CLUTCH GEAR | 050202 | |
| 03 | 1 | DIFFERENTIAL CASE | 011403 | |
| 04 | 1 | RETURN SPRINGS (PK OF 4) | 150101SP | |
| 05 | 1 | RETAINING PIN SET (PK OF 4) | 120303SP | |
| 06 | 1 | LONG CROSS SHAFT | 060205 | |
| 07 | 2 | SHORT CROSS SHAFT | 060402 | |
| 08 | 1 | PISTON | 040202SP | |
| 09 | 1 | ANNULAR SEAL | 160905SP | |
| 10 | 1 | CYLINDER CAP ASSEMBLY | 030603 | |
| 11 | 1 | CYL CAP RETAINING BOLT (PK OF 8) | 200205SP | |
| 12 | 1 | LOCKING TAB (8mm) (PK OF 8) | 150401SP | |
| 13 | 1 | TAPERED ROLLER BEARING | NOT SUPPLIED | |
| 14 | 1 | SEAL HOUSING RETAINING CLIP | 150601SP | |
| 15 | 1 | SPLINED SIDE GEAR | SEE NOTE | 2 |
| 16 | 1 | PINION THRUST WASHER (PK OF 4) | 151102SP | |
| 17 | 4 | PINION GEAR | SEE NOTE | 2 |
| 18 | 1 | SPIDER BLOCK | 070201SP | |
| 19 | 1 | SIDE GEAR | SEE NOTE | 2 |
| 20 | 1 | S GEAR THRUST WASHER (PK OF 2) | 151002SP | |
| 21 | 1 | ADJUSTER NUT | 100101SP | |
| 22 | 1 | SEAL HOUSING KIT | 081902SP | |
| 23 | 1 | SEAL HOUSING O-RINGS (PK OF 2) | 160235-2 | 1 |
| * | 1 | BULKHEAD FITTING KIT (O-RING TYPE) | 170111 | |
| * | 1 | PUSH-IN FITTING (5mm to 1/8"BSPP) | 170201SP | |
| * | 1 | AIR LINE (5mm DIA X 6m LONG) | 170301SP | |
| * | 1 | SOLENOID VALVE (12V) | 180103 | |
| * | 1 | SWITCH RR LOCKER | 180224 | |
| * | 1 | CABLE TIE (PK OF 25) | 180305 | |
| * | 1 | OPERATING & SERVICE MANUAL | 210200 | |
| * | 1 | INSTALLATION GUIDE | 210225 | |

* *Not illustrated in exploded view*

NOTES

- 1 For replacement O-rings use only BS133 Viton 75.
- 2 Available only as complete 6 gear set # 728A064
- For information on RD25 models with metal pistons, contact ARB.
- For seal housing set-up refer to tech notes (Section 5.1 & 5.2).
- For the large Mitsubishi 28 spline differential with a thrust block between the axle shafts (available on drum brake equipped vehicles) refer to RD46 (Section 2.46).
- For the 'small' Mitsubishi 28 spline rear differential with 10 ring gear bolts refer to RD05 (Section 2.5).

RD25

Mitsubishi 9",RR,28 SPL,disc brake**

****THIS MODEL WAS SUPERSEDED BY RD212, CROSSED OUT PARTS NOT AVAILABLE**

EXPLODED DIAGRAM

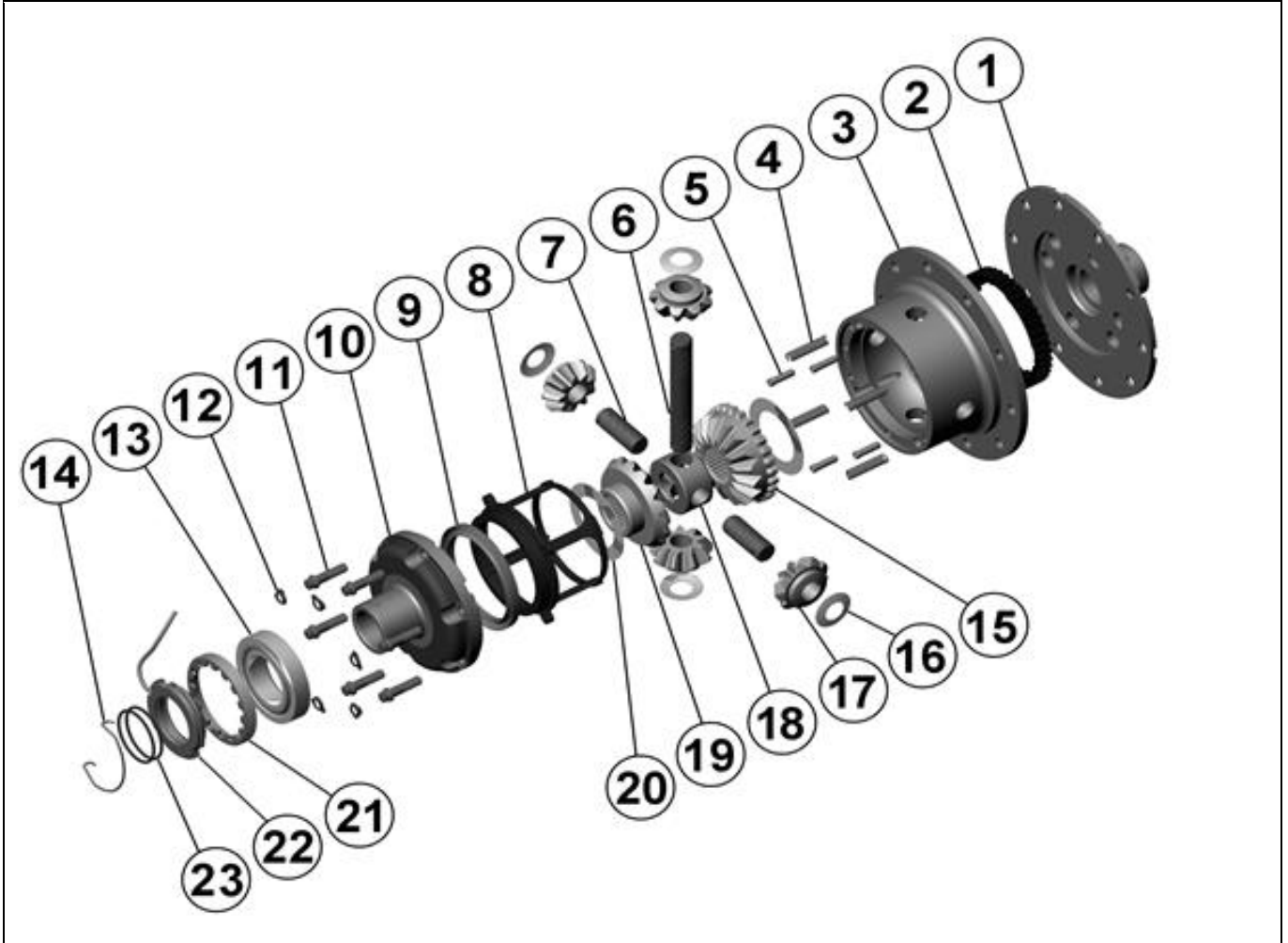

SPECIFICATIONS

| | |
|--------------------|----------------------------|
| Axle Spline | 28 tooth, Ø30.5mm [1.20"] |
| Ratio Supported | All |
| Ring Gear ID | 145.0mm [5.71"] |
| Ring Gear Bolts | 12 bolts on Ø175mm [6.89"] |
| Ring Gear Torque | 85Nm [63 ft-lb] |
| Backlash | 0.13-0.18mm [0.005-0.007"] |
| Bearing Cap Torque | 60Nm [44 ft-lb] |

ARB Corporation Ltd • 42-44 Garden St Kilsyth VIC 3137 Australia
ARB 4X4 Accessories USA • 720 SW 34th St Renton WA 98057 USA
Australia & International Customer Service • +61 3 9761 6622
North America Customer Service • Toll Free 866 293 9078
www.arb.com.au (AUS & Int) www.arbusa.com (N. America)

