

ARB AIR LOCKER *Air Operated Locking Differentials*

CKSA12 On-Board Air Compressor Kit

ITEM #	QTY	DESCRIPTION	PART #	NOTES
01	3	HEAD BOLT	310202	
02	1	HEAD ASSEMBLY	310102	
03	1	BARREL O-RING	---	1
04	1	BARREL	310201	
05	1	BARREL GASKET	---	1
06	1	PISTON/COUNTERWEIGHT ASSEMBLY	310103	
07	1	CRANKCASE COVER GASKET	---	1
08	1	CRANKCASE COVER	---	2
09 & 16	1	COVER BOLTS (M4 HEX FLANGE)	310203	
10	1	AIR FILTER ASSEMBLY	300501	7
11	1	AIR FILTER ELEMENT	300502	5
12	2	SOLENOID ASSEMBLY	NOT SUPPLIED	
13	1	PRESSURE SWITCH	CO35	
14	2	PLUG (1/8" BSPT)	170802	4
15	1	MANIFOLD O-RING	---	1
17	1	MOTOR/CRANKCASE ASSEMBLY	---	2
18	2	MOTOR BOLT O-RING	---	1
19	1	MANIFOLD COVER	---	2
20	2	MOTOR BOLT	---	2
21	1	MOTOR MOUNT ASSEMBLY	310101	
22	4	MOUNTING BOLT	200405	
23	2	MOTOR MOUNT CLAMPING NUT	---	3
24	1	COMPRESSOR BACKING PLATE	290603	
25	4	MOUNTING NUT	6151223	
26	2	MOTOR MOUNT CLAMPING BOLT	---	3
*	1	SWITCH w/ COVER (12V LED)	180222	
*	1	WIRING LOOM,CKSA12	180408	6
*	1	INSTALLATION GUIDE	2102SA12	

* *Not illustrated in exploded view.*

NOTE: The air filter should be cleaned regularly. To do this, unclip the filter cover (10) and remove the element (11). Wash in hot, soapy water, rinse and let dry completely. Reinsert the element into the base. Wipe out the cover and clip firmly back into place.

All screws in this unit have been thread locked using a special high heat compound. Dis-assembly of this unit should only be attempted using a heat gun or micro torch to pre-heat each thread prior to loosening it.

The compressor manifold must be periodically removed to clean out any condensation, etc. To do this, bleed off any residual pressure that may be in the manifold. Remove the 4 cover bolts at the end of the manifold and the 3 head bolts (01). Remove the manifold and wipe out any moisture. If there is excessive moisture in the manifold then it should be cleaned out more regularly. Refit the manifold making sure that the O-rings are in their correct position. Torque the bolts up to 1.28Nm [0.94ft-lb]. Do not over tighten. Run the compressor and check for any air leaks.



Specs:

Voltage	12 Volts
Current Draw	No-Load 5A Load 6.5A
Air Flow	25.0L/min @ 0kPa [0.88CFM @ 0psi] 13.4L/min @ 200kPa [0.47CFM @ 200psi]
Total Weight	2.1kg [4.6lbs]
Size	122mm x 162mm x 188mm [4.8" x 6.4" x 3.5"]
Manifold Port	1/4" npt [Pressure Switch] 1/8" bspt [Solenoid nipple]
Pressure Switch	Open 690kPa [100psi] Closed 490kPa [70psi]

Notes:

- 1 Available only in CKS SEAL KIT #310104.
- 2 Not available separately.
- 3 Available only as included with MOTOR MOUNT ASSEMBLY #310101.
- 4 Included x2 in HEAD ASSEMBLY #310102.
- 5 Available only in packs of 3.
- 6 For wiring diagram refer to **Section 5.8**.
- 7 AIR FILTER ASSEMBLY comes complete with one AIR FILTER ELEMENT (Item #11)

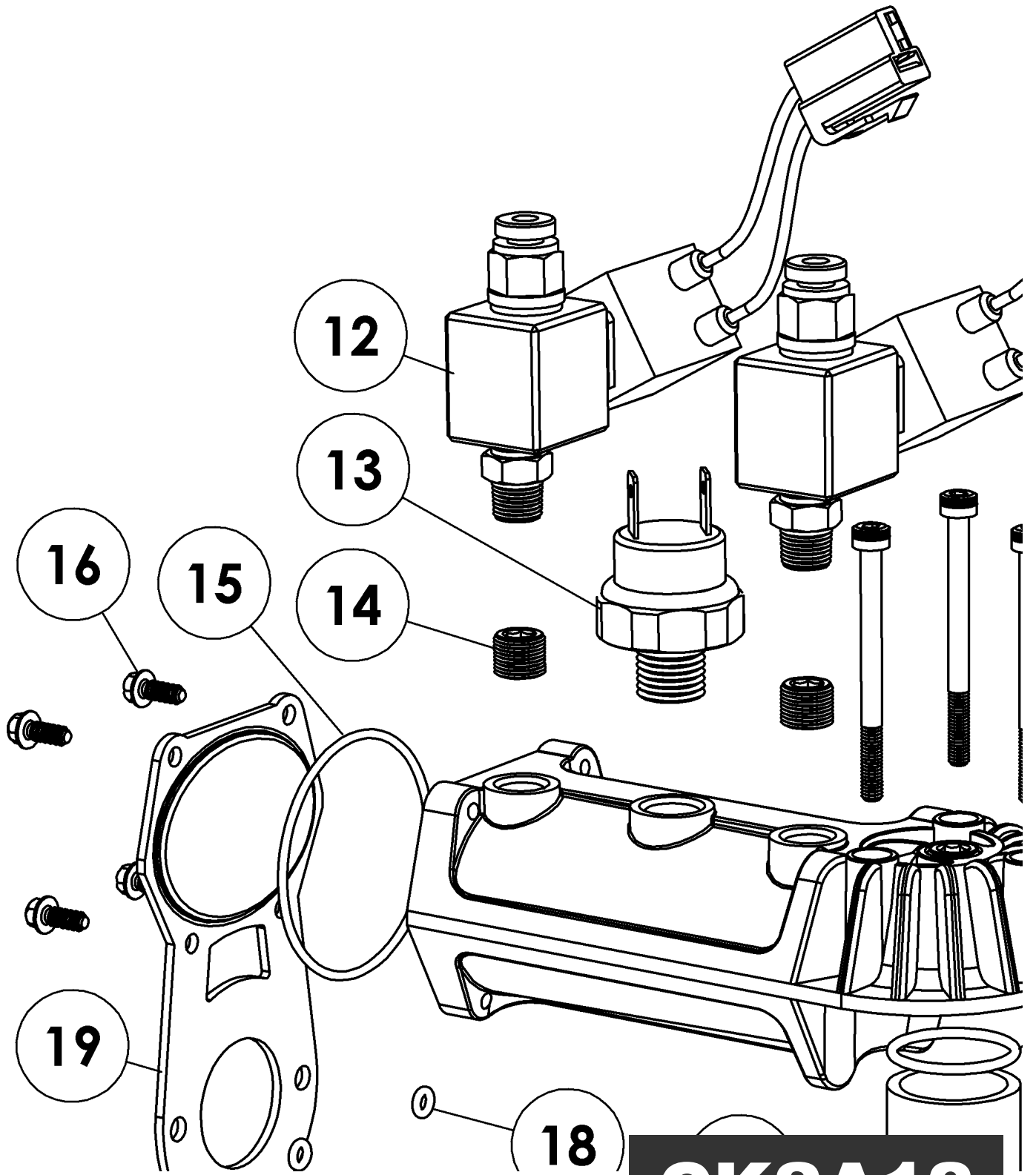

CKSA12