

ARB AIR LOCKER *Air Operated Locking Differentials*

290311 RD Compressor Piston Service Kit

ITEM #	QTY	DESCRIPTION	PART #	NOTES
08	1	BARREL	290309	
14	1	PISTON/CONROD ASSEMBLY	290310	
*	1	SHIM 0.2mm [0.008"]	150501	1
*	1	SHIM 0.4mm [0.016"]	150502	1
07	1	HEAD O-RING	160214	
*	2	PISTON RING	290302	
*	1	BACKING O-RING	160213	
*	1	INSTALLATION GUIDE	210508	

Specs:

Suits RDCKA, RDCKA24, RDCP, RDCPA

Notes:

- 1 Shims required only for deck height adjustment.

* Not illustrated in exploded view.

INSTALLATION:

1. Remove compressor air filter cover (01), air filter (02) and hex head screws (03).
2. Remove the air filter base (04) and pay particular attention to the exhaust valve assembly (09-11), as these components are now loose. If this assembly falls out, refer to diagram opposite for reinstallation.
3. Remove cylinder head bolts (05) and carefully remove cylinder head (06) and the head O-ring (07). Discard the old O-ring.
4. Remove crankcase cover plate (12) and the cap screw (13) securing the piston and conrod assembly (14) to counterweight (15). Check between the piston/conrod assembly and the counterweight for a washer. If this washer is present, it must also be used in the rebuild.
5. Remove the barrel (08), piston and conrod as an assembly and discard.
6. Clean the cap screw (13) threads and apply Loctite 272 as per tube instructions.
7. Fit new piston/conrod assembly (with washer between conrod and counterweight if applicable – see step 4) to counterweight with the cap screw and using a torque wrench, tighten to 11Nm [8 ft-lb].
8. Carefully fit barrel over piston ensuring the piston rings are not damaged in the process.
9. With barrel fully seated on crankcase, rotate motor through 360 degrees (one full turn) and bring the piston to top dead centre (TDC).
10. Measure the deck height (see Fig. 1) with a depth micrometer, to ensure the distance of the piston crown to the top of the barrel is within specification. Deck height 0.5mm $+0.2/-0.0$ [0.020" $+0.008/-0.000$].
11. If deck height is not within specification, insert one of the supplied shims below the barrel to adjust.
12. Recheck deck height.
13. Clean the cylinder head bolt threads and apply Loctite 272 as per tube instructions.
14. Fit new O-ring with the cylinder head and secure the bolts, torqued to 9Nm [7 ft-lb] in a 1,3,4,2 sequence (diagonal pattern).
15. Refit crankcase cover plate and air filter base ensuring exhaust valve assembly is installed complete and correct. Refit air filter (smooth side down) and air filter cover.
16. Test run compressor and check for correct operation.

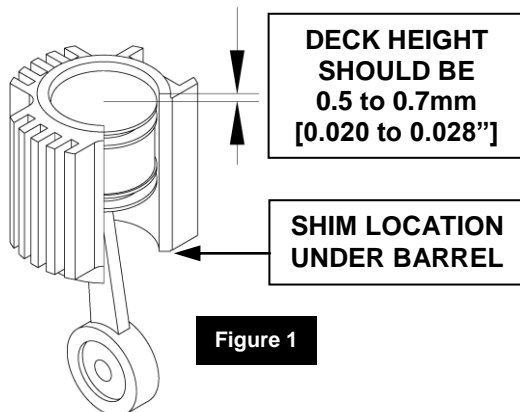
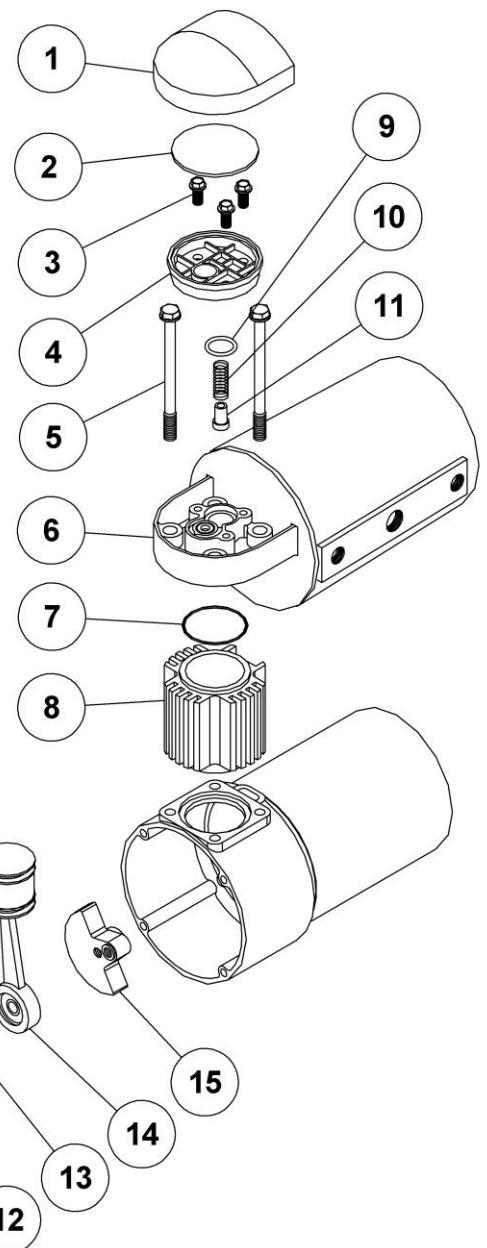

290311

ARB AIR LOCKER *Air Operated Locking Differentials*

320303 CKM Compressor Piston Service Kit

ITEM #	QTY	DESCRIPTION	PART #	NOTES
08	1	BARREL	320201	
09	1	PISTON ASSEMBLY	320103	
10	1	AXLE, M5	320203	
10	1	AXLE, M6	320232	
*	2	RETAINING RING DIN7993 RW-14	6151767	
11	1	CAP SCREW (M5 X 20mm)	200711	1
11	1	CAP SCREW (M6 X 25mm)	200718	1
*	1	INSTALLATION GUIDE	210516	

* Not illustrated in exploded view.

PISTON REMOVAL:

1. Unscrew the air filter assembly. Remove air filter flange bolts (13), air filter flange (12) and O-ring (14).
2. Remove head bolts (01) and head assembly (02). On CKMA models the bolts securing the manifold support bracket will also need to be removed.
3. Remove the BARREL (08). Place a screwdriver under the head of the piston as shown in Fig.1. This will stop the piston from moving through a full stroke.
4. Heat the CAP SCREW (11) using a micro torch to release the thread lock, unscrew it in an anti-clockwise direction, extract it along with the AXLE (10).
5. Lift the PISTON ASSEMBLY (09) from the compressor motor.
6. Discard the PISTON ASSEMBLY, BARREL, AXLE and CAP SCREW.

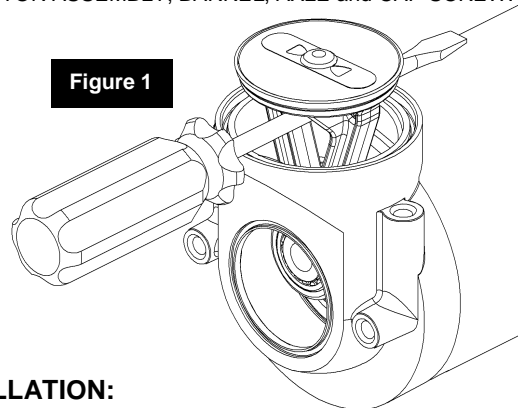

Figure 1

PISTON INSTALLATION:

7. Ensure the pocket that the AXLE sits in is clean and free from damage.
8. With the new PISTON ASSEMBLY (09) and BARREL (08) assembled together, put them in place on the compressor motor.

NOTE: Be careful not to damage to the piston seal. The seal forms a cup shape and must be assembled into the barrel in the correct direction. Place the bearing end of the piston into the barrel first then pull the piston into the barrel as shown in Fig. 2.

9. Holding the AXLE (10) by the wire ring, align the piston bearing then insert through the bearing so that it seats firmly into the pocket in the motor.
10. Apply high temperature thread lock (ie. Loctite 272) to the CAP SCREW. Insert the screw through the AXLE into the motor and tighten by hand.
11. Using a torque wrench tighten the M5 CAP SCREW (11) to 10.0Nm (7.4 ft-lb), or the M6 CAP SCREW (11) to 13.0Nm (9.6ft-lb). Use the same technique with the screwdriver as in step 3 to prevent the piston from moving through a full stroke.
12. Re-assemble the remaining components by reversing steps 1 and 2.
13. Allow 120 minutes fixture time for the thread lock before operating the compressor.

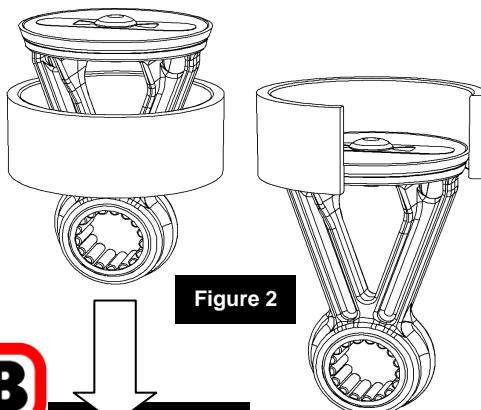

Figure 2

Specs:

Suits CKMA12, CKMA24, CKMP12

Notes:

1. Select the cap screw to match the size of the one being replaced

O-ring seals are available as O-ring Seal Kit #320301.

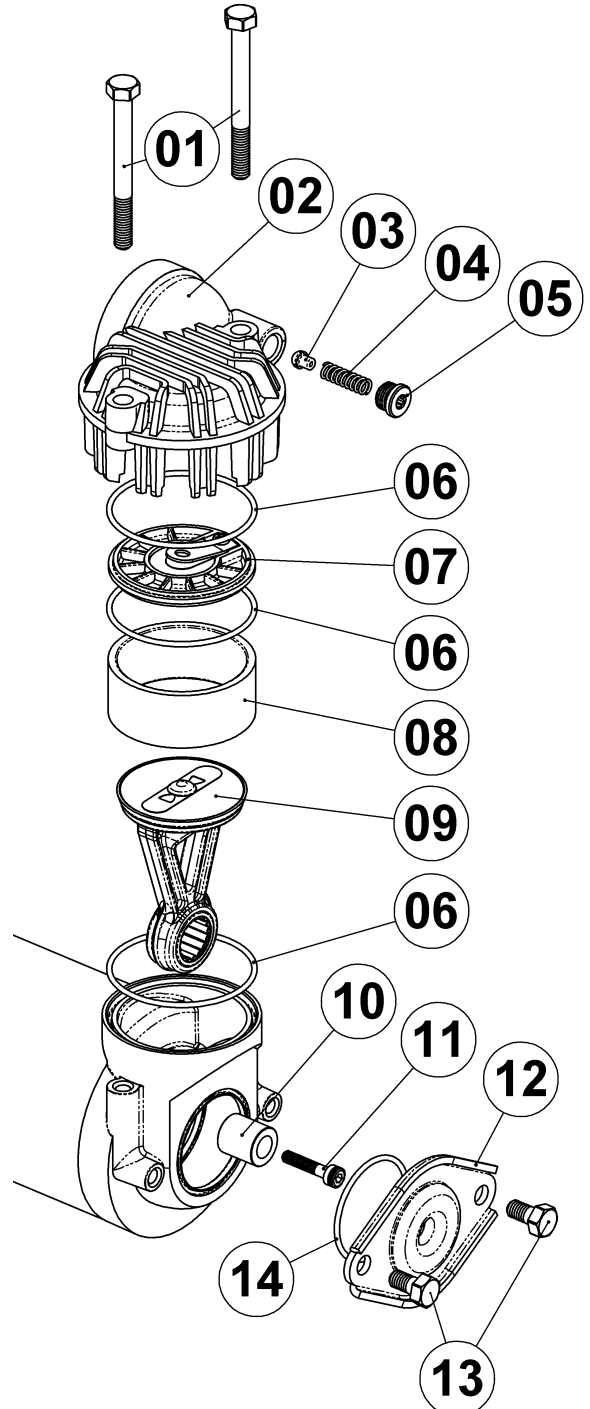

320303

Revision Date 4/09/17

