



# RD224

**NISSAN M205, 30 SPLINE**

---

**AIR OPERATED  
LOCKING DIFFERENTIAL  
INSTALLATION GUIDE**

---

No liability is assumed for damages resulting in the use of the information contained herein.  
*ARB AIR LOCKER* Locking Differentials and *AIR LOCKER* are trademarks of ARB Corporation Limited.  
Other product names used herein are for identification purposes only and may be trademarks of their respective owners.

---

# **ARB 4x4 ACCESSORIES**

## **Corporate Head Office**

**42-44 Garden St  
Kilsyth, Victoria  
AUSTRALIA  
3137**

**Tel: +61 (3) 9761 6622  
Fax: +61 (3) 9761 6807**

**Australian enquiries  
North & South American enquiries  
Other international enquiries**

**sales@arb.com.au  
sales@arbusa.com  
exports@arb.com.au**

---

**www.arb.com.au**

## Table of Contents:

<b>1</b>	<b>Introduction</b>	<b>3</b>
1.1	Pre-Installation Preparation	3
1.2	Tool-Kit Recommendations	4
<b>2</b>	<b>Removing the Existing Differential</b>	<b>5</b>
2.1	Vehicle Support	5
2.2	Differential Fluid Drain	5
2.3	Removing the Axles and Differential	5
2.4	Marking the Bearing Caps	6
2.5	Checking the Current Backlash Amount	7
2.6	Removing the Differential Carrier	8
<b>3</b>	<b>Installing the Air Locker</b>	<b>9</b>
3.1	Mounting the Ring Gear	9
3.2	Installing the Carrier Bearings	11
3.3	Drilling and Tapping the Bulkhead Port	12
3.4	Modifying the Bearing Cap	13
3.5	Modifying the Adjuster Nut (Post 2009)	14
3.6	Installing the Seal Housing	15
3.7	Final Air Locker Assembly	16
3.8	Checking the Backlash	17
3.9	Setting up the Bulkhead Fitting	18
3.10	Profiling the Seal Housing Tube	20
3.11	Bench Testing the Air Locker	21
3.12	Reinstalling the Differential & Axles	22
<b>4</b>	<b>Installing the Air System</b>	<b>23</b>
4.1	Mounting the Solenoid	23
4.2	Running & Securing the Air Line	25
4.3	Connection to the Bulkhead Fitting	26
<b>5</b>	<b>Mounting &amp; Connecting the Electrical System</b>	<b>28</b>
5.1	Mounting the Actuator Switch(es)	28
5.2	Wiring the Actuator System	29
<b>6</b>	<b>Testing &amp; Final Assembly</b>	<b>32</b>
6.1	Leak Testing	32
6.2	Testing the Air Locker Actuation	32
6.3	Filling the Differential	33
6.4	Post-Installation Check List	34
<b>7</b>	<b>Parts List</b>	<b>35</b>
7.1	Exploded Assembly Diagram	35
7.2	Specifications	35
7.3	Itemized Parts List	36



# 1 Introduction

## **IMPORTANT :**

**BEFORE ATTEMPTING TO DISMANTLE YOUR VEHICLE FOR THIS INSTALLATION, PLEASE READ THIS INSTALLATION GUIDE IN ITS ENTIRETY, AS WELL AS ALL APPLICABLE SECTIONS OF YOUR VEHICLE MANUFACTURER'S SERVICE MANUAL.**

### 1.1 Pre-Installation Preparation

This booklet is to be used in conjunction with your vehicle manufacturer's service manual. ARB endeavors to account for every possible variation in vehicle model when publishing its installation guides, and guides are updated regularly as new model information becomes available, however, the rapid and globally varied release of some vehicles makes it difficult to insure that your vehicle model has been accurately accounted for. In the case of any technical discrepancies between this guide and your service manual, we strongly advise that you adhere to the specifications and techniques as documented in your service manual.

Although your *ARB Air Locker* comes complete with all the step by step instructions you will need to supplement your vehicle manufacturer's service manual and install your new differential, ARB recommends that you have your *Air Locker* installed by a trained professional. Many ARB distributors around the world have been fully instructed in *Air Locker* installations by ARB, and have gained a wealth of experience and skill from years of performing similar installations.

Once you begin this installation your vehicle will be immobile until all steps of the installation are complete. Make sure your *Air Locker* kit is the correct model for your vehicle and that it contains all of the parts listed on back cover of this booklet. Also be sure you have appropriately equipped yourself with all the necessary tools, parts, and materials to complete this installation (see Section 1.2 *Tool-Kit Recommendations*), and that you have allowed for an appropriate amount of vehicle down time.

#### **HINT :**

Place a ✓ mark inside each of the  symbols as you complete each step. It is very important NOT to miss any of the steps!



# 1 Introduction

## 1.2 Tool-Kit Recommendations

Below is a list of tools and supplies you may need to complete this installation. Requirements for your vehicle may vary. Please consult your vehicle service manual for additional recommendations.

### 1.2.1 Tools

- Standard automotive sizes (metric and/or imperial) of sockets, wrenches, Allen keys, and drills.
- A dial indicator or other suitable measuring tool for checking ring & pinion backlash.
- An automotive brake tubing cutter to cut the copper tubing.
- An adjuster-nut wrench (e.g., ARB Adjuster Nut Pliers #0770002)
- A razor knife suitable for cutting nylon tubing.
- A torque wrench (See your vehicle service manual for the required torque range).
- A lubricant drain reservoir.
- An 11.2mm [7/16"] drill and ¼"NPT tap for bulkhead fitting installation.
- An automotive bearing puller (e.g. ARB Bearing Puller #0770001) or a differential carrier bearing puller.
- A soft hammer (e.g., copper or nylon).
- A bearing press or arbor press.
- A 46mm [1-13/16"] socket or equivalent for adjuster nut preloading.
- A socket extension bar to reach 300mm (12").

### 1.2.2 Supplies

- Thread lubricant/sealant compound for pressure fittings (e.g., LOCTITE #567 Teflon paste)
- Thread locking compound (e.g., LOCTITE #272)
- A gasket sealant or replacement gasket for your third member.
- A sufficient volume of differential oil to completely refill your housing (See the *ARB Air Locker Operating and Service Manual* for recommended lubricants).
- A soap and water mixture to test for air leaks.

## 2 Removing the Existing Differential

### 2.1 Vehicle Support

- Safely secure the vehicle on a hoist. We recommend supporting the vehicle on a chassis hoist to keep the differential area at a convenient working height and to leave the wheels and axles free to be rotated and removed.
- Once supported off the ground, release the parking brake and leave the vehicle in neutral. Chock the wheels if necessary.

### 2.2 Differential Fluid Drain

- Clean around the differential drain plug to prevent dirt from entering the differential.
- Position a fluid drain reservoir under the differential and loosen the differential drain plug.
- Completely drain all differential fluid.
- Once drained, reinstall the drain plug finger tight to prevent drips coming out of the housing and dust getting in.

**HINT :** This is a good time to check for metal particles in your oil and in the bottom of the housing which may indicate a worn bearing or differential component.

### 2.3 Removal of the Axles and Differential

- Remove the CV axles according to your vehicle's service manual.
- Disconnect the drive shaft from the flange of the differential.
- Drop the entire front differential assembly from the vehicle according to your service manual.

#### **IMPORTANT :**

Collision damage or heavy off-road use of your vehicle in the past may have resulted in some degree of bending in the axle. Any misalignment of the axle tubes may result in excessive wear and/or failure of your differential and axle shafts. ARB strongly recommends that you have your axle assembly inspected for concentricity and straightness before installing your *Air Locker*.

## 2 Removing the Existing Differential

### 2.4 Marking the Bearing Caps

- Using a small pointed center punch, gently mark the bearing caps in a way that will enable you to know which cap is 'LEFT' and which cap is 'RIGHT', which way is 'UP' and which way is 'DOWN'. (Fig.1.)
- Mark the right hand cap in a similar way.

**HINT :** Many installers choose to make one punch mark on the left hand side of the left hand bearing cap and a similar mark on the housing at close proximity to the cap mark. The right hand side is then designated with two punch marks on the right hand side of the cap and two similar punch marks on the housing.





## 2 Removing the Existing Differential

### 2.5 Checking the Current Backlash Amount

#### **IMPORTANT:**

This step is a precautionary measure recommended by ARB due to the fact that some aftermarket ring and pinion sets have been manufactured to run with different backlash settings than those specified by your vehicle manufacturer. Although ARB must recommend you set backlash according to your service manual guidelines, we also advise that you compare the backlash measurements taken here to the recommended backlash settings in your vehicle service manual. Measurements found to be outside of your service manual recommendations may indicate the need to deviate from those settings in order to achieve quiet running with a good contact mark.

Refer to your vehicle service manual or your local authorized ARB installer for more information.

- Set a dial indicator on one of the ring gear teeth. (Fig.2.)



- While supporting the pinion gear by holding the pinion flange, rotate the differential in both directions while observing the maximum variation in depth from the indicator (i.e., the highest value minus the lowest value). This value is referred to as the ring and pinion backlash.
- Rotate the differential center 90° and measure again for accuracy.
- Record the average of all measurements.

## 2 Removing the Existing Differential

### 2.6 Removing the differential carrier

- Remove the long axle shaft.
- Loosen the adjuster nut locking screws.
- Remove the bearing caps.
- Using the supplied hex tool on an extension bar for the ring gear side, and a 46mm socket for the case side, loosen the adjuster nuts.

**NOTE :** The supplied hex tool is only for vehicles built prior to September 2009.

- Carefully remove the differential carrier from the housing.
- Remove the tapered roller bearings from the differential carrier with a bearing puller. (Fig.3.)
- Keep the bearings separate, ensuring you know which is from the flange (LH) side and which from the case (RH) side.

**HINT :** Check the condition of the bearings for wear and replace if necessary.



## 3 Installing the Air Locker

### 3.1 Mounting the Ring Gear

- Remove the bolts that hold the ring gear in place.
- Using a soft mallet or copper hammer, tap in a circle around the ring gear to separate it from the differential carrier.
- Thoroughly clean any thread locking compound or other foreign matter from the holes of the ring gear, the threads of the ring gear bolts, the mating surfaces of the ring gear and the *Air Locker* flange.

**HINT :** Rubbing the ring gear mounting face with a flat oil stone before installation will remove any high spots around the threads.

- Heat the ring gear to between 80 and 100°C (175 - 212°F) in hot water or in an oven to slightly expand the gear and facilitate assembly.

**NOTE :** **NEVER HEAT GEARS WITH A FLAME!** This could damage the hardened surface of the gear and result in premature wear or failure.

- Dry the gear and tapped holes with compressed air (if wet).
- Apply a thin film of high-pressure grease to the ring gear shoulder of the *Air Locker* to prevent seizing.
- Install the ring gear onto the *Air Locker* by aligning the tapped holes and then gently tapping it around in a circle with a soft mallet or hammer. Avoid using the bolts to pull the ring gear down as this puts excess strain on the bolts and the differential flange.
- Apply a thread locking compound (e.g., Loctite 272) to the thread of each ring gear bolt before inserting it. Do not apply locking compound directly into the threaded hole as this could prevent the bolt from reaching its full depth.

**NOTE :** On some models, the crown wheel bolts cannot be reused and should therefore be replaced. Refer to your vehicle manufacturer's service manual for details.

- Tighten the ring gear bolts in a star pattern with a torque wrench (Fig.4.) set to your vehicle manufacturer's specified torque.

### 3 Installing the Air Locker



### 3 Installing the Air Locker

#### 3.2 Installing the Carrier Bearings

- With the *Air Locker* well supported in an arbor press, apply a thin film of high pressure grease to both bearing journals.
- Press the flange side tapered roller bearing cone onto the LH bearing journal of the *Air Locker* until the bearing seats firmly against the bearing journal shoulder.

**NOTE :** Never re-use any bearings which are damaged or worn.

- Invert the *Air Locker* and press the case side bearing cone onto the RH bearing journal until the bearing seats firmly against the bearing journal shoulder (Fig. 5.).

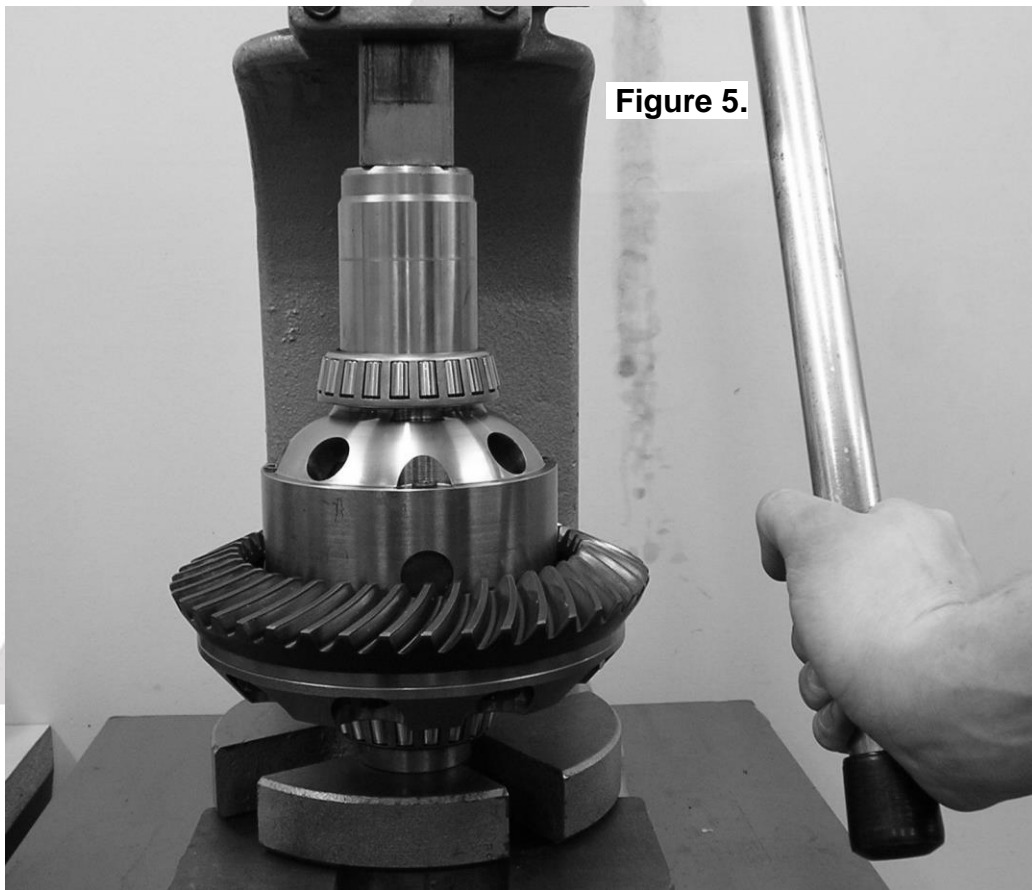

Figure 5.



## 3 Installing the Air Locker

### 3.3 Drilling and Tapping the Bulkhead Port

An air line port must be drilled and tapped through the differential housing to mount the bulkhead fitting into.

- Mark a spot for the bulkhead port on the case in the position shown below, 50mm from the front face. Ensure that is in an area that will be well clear of the ring gear, the differential, and any other obstructions that may snag the seal housing tube. (Fig. 6.)

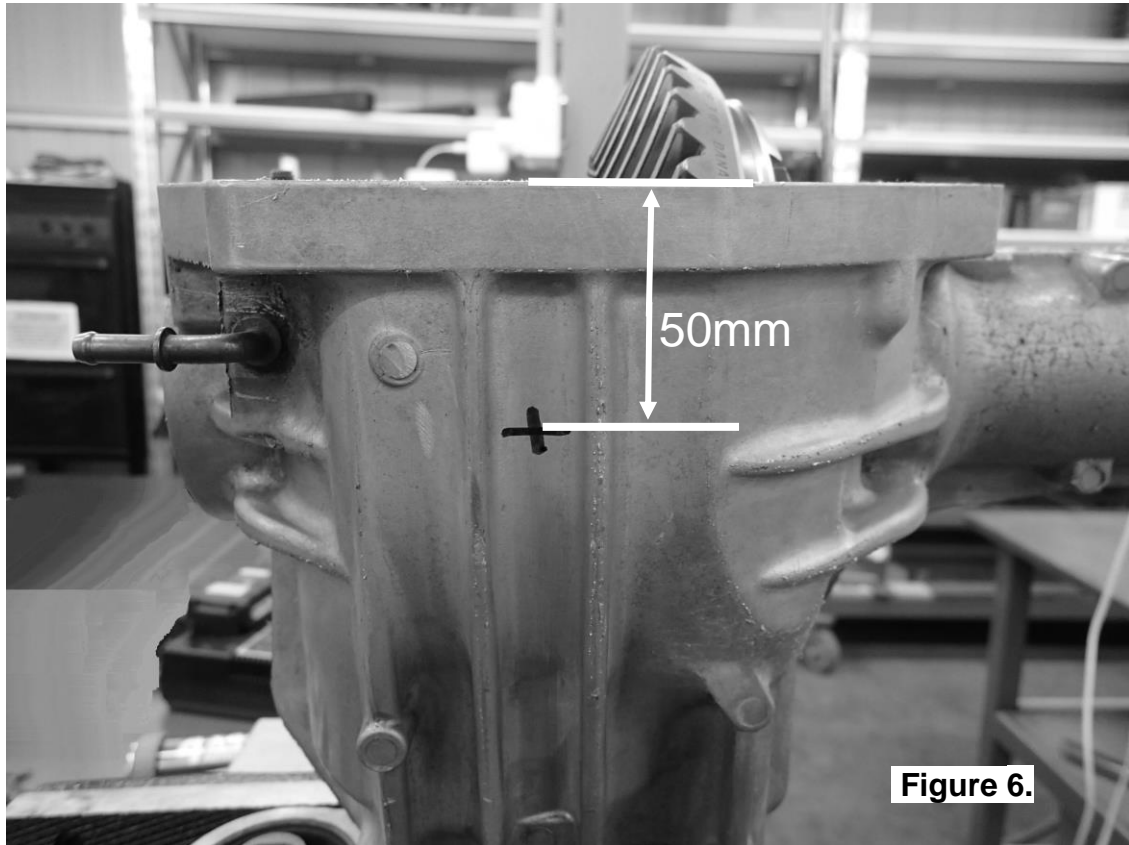

Figure 6.

- Cover the drive pinion and axle tube areas with a rag to protect them from metal filings.
- Pilot drill a hole on the center of the marking, then drill an 11.2mm [7/16"] hole through.
- Tap the hole from the outside using 1/4"NPT thread tap.
- Remove any sharp edges that may chip off from around the hole and fall into the housing.
- Very carefully, remove the rags and inspect with a service light inside the housing to ensure no metal filings are left behind.

### 3 Installing the Air Locker

#### 3.4 Modifying the Bearing Cap

In order to clear the seal housing tube, a groove will need to be filed at 30° on the outside face (axle tube side) of the flange side bearing cap as shown below (Fig. 7. & 8.).

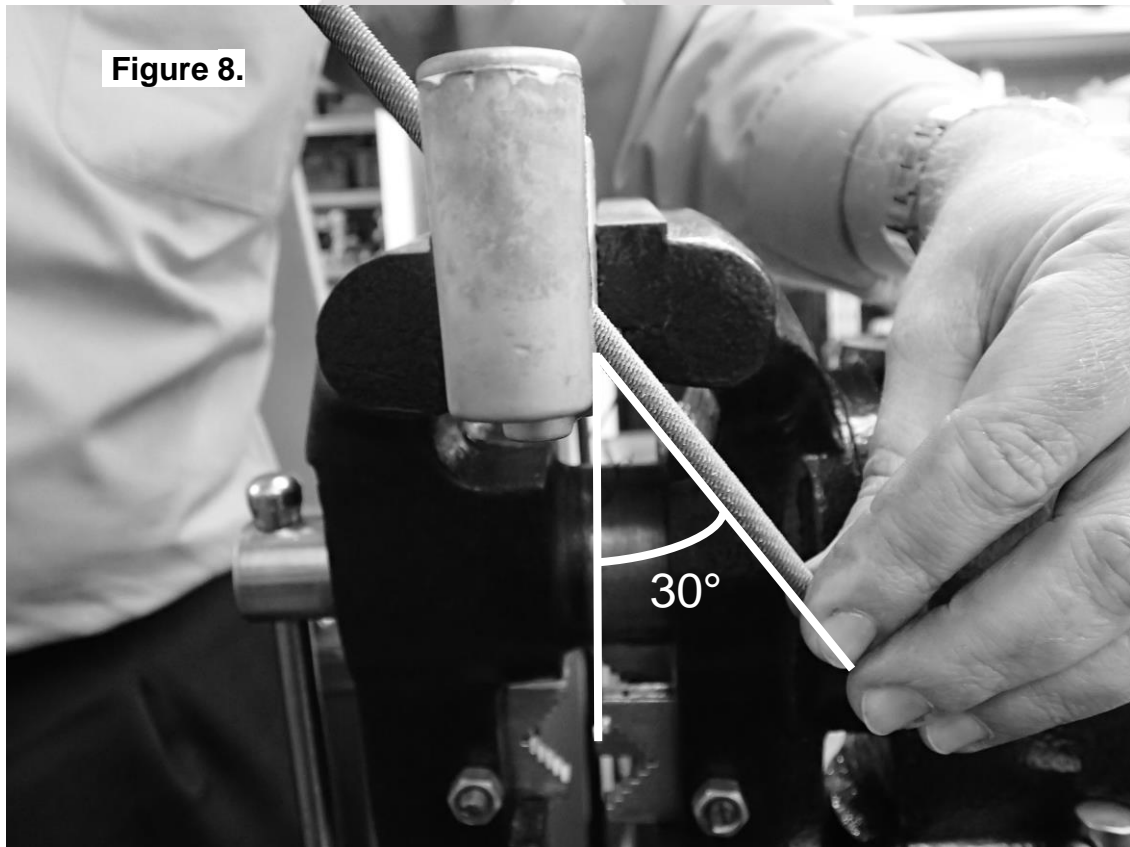

### 3 Installing the Air Locker

#### 3.5 Modifying the Adjuster Nut (post 2009)

Nissan vehicles with M205 differential assemblies built after September 2009 will require modification of the flange cap side adjuster nut to aid installation of the *Air Locker*. The supplied hex tool will not be able to be used on this new version of the nut and a socket (not supplied) will have to be used instead.

- Remove flange cap side adjuster nut from the assembly.
- Machine or grind a 4mm x 45° chamfer as shown in Figure 9. This will ensure that the nut can be threaded far enough into the housing to allow installation of the *Air Locker*.

**Figure 9.**

Machine or grind  
4mm x 45° CHAMFER

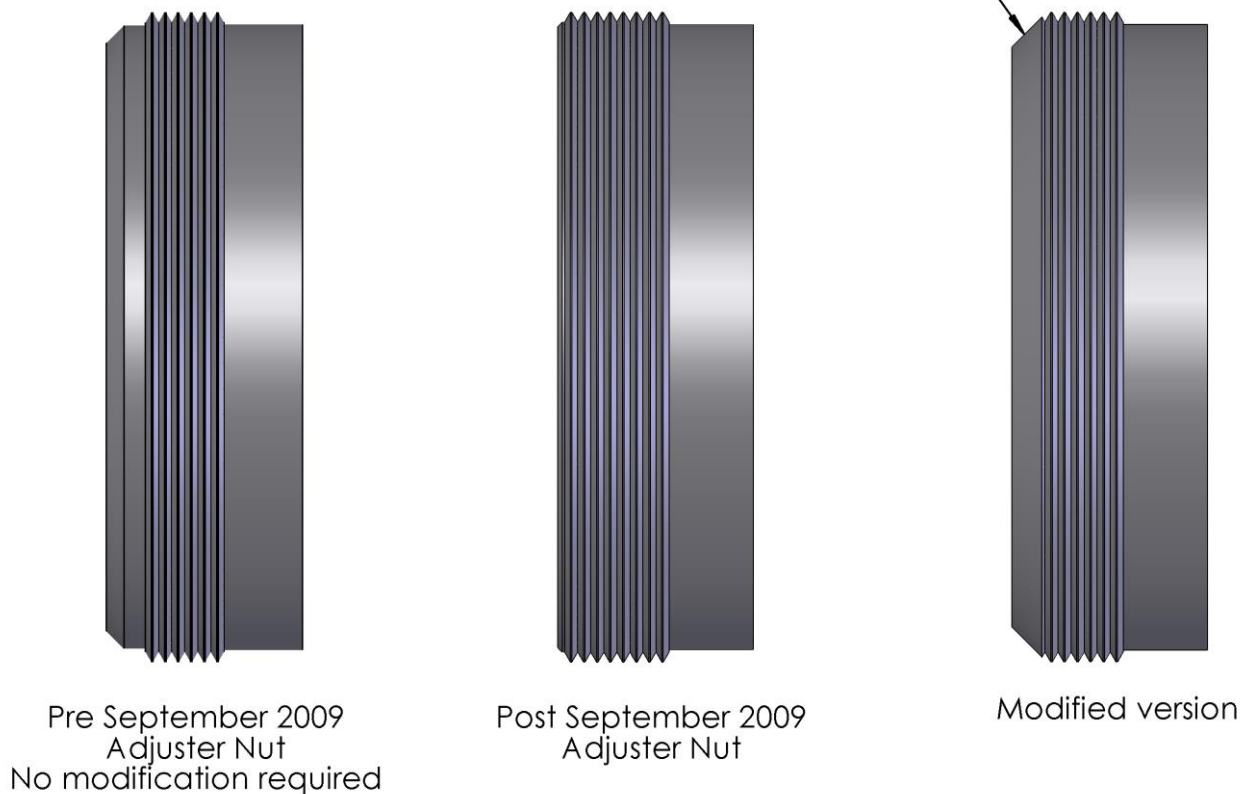

- Thoroughly clean any grinding dust or swarf from the nut, and re-install it back into the housing.



## 3 Installing the Air Locker

### 3.6 Installing the Seal Housing

- Make sure the grooves and airway of the seal housing are clean and free from any contaminants (e.g. water, dirt, metal filings, etc.).
- Inspect the seal housing O-rings (supplied) for dirt, damage or other conditions which might cause leaks.
- Generously lubricate the O-rings with oil prior to assembly, then insert them into the grooves of the seal housing.

**NOTE :** When assembling the O-rings, be careful not to leave them twisted when seated in the grooves as this could cause excessive wear and leakage.

- Lubricate the seal housing running surface on the *Air Locker* carrier with oil.
- Assemble the bearing cups onto the diff, then carefully install the seal housing by sliding it all of the way onto the bearing journal with a gentle twisting motion until it sits flat against the bearing cup.

**NOTE :** A twisting motion (i.e., a slight rotation while pressing the seal housing on) will allow the O-rings to engage gently and prevent them from twisting. Twisted O-rings will result in pre-mature O-ring wear and oil contamination in the air system due to the helical shape formed by the O-ring mould line.

- Bend the seal housing as shown in Figure 10. so that it will clear the bearing cap on installation.



**Figure 10.**

## 3 Installing the Air Locker

### 3.7 Final Air Locker Assembly

- Using the provided hex tool on an extension bar, loosen the flange side adjuster nut so that it is as far into the axle tube as it will go (away from the differential) to give extra room for the *Air Locker*. Use a socket to loosen the case side nut as far as it can go.
- Place the *Air Locker* into the differential housing and install the bearing caps.

**NOTE :** Be sure to check that the bearing caps are on the correct sides of the third member and are correctly aligned.

**NOTE :** Make sure the seal housing tube is aligned with the groove in the bearing cap, and that there is adequate clearance between the two.

- Insert the bearing cap bolts and hand tighten.
- Use the hex tool on an extension bar and tighten the flange side adjuster nut into the ring gear side bearing cap. Be very careful not to twist the seal housing and damage the tube.

**NOTE :** You should feel no backlash between the ring and pinion gears once the adjuster nut tightens.

- Reverse the adjuster nut (counterclockwise) ¼ turn.
- Using a 46mm socket, screw the case side adjuster nut into the differential until it seats against the bearing, and add the appropriate amount of preload.

**NOTE :** You should now feel some backlash between the ring and pinion gears. If not, there might be a clearance problem which is binding the carrier. Re-check the clearance.

**IMPORTANT:**

You **MUST** preload the differential from the case side adjuster nut. Preloading from the flange side nut will cause damage to the seal housing.

## 3 Installing the Air Locker

### 3.8 Checking the Backlash

- Set a depth indicator on one of the ring gear teeth (Fig.11.).
- While supporting the pinion gear by holding the drive shaft flange, rotate the differential in both directions while observing the maximum variation in depth from the indicator (i.e., the highest value minus the lowest value). This value is referred to as the ring and pinion backlash.
- Rotate the differential center 90° and measure again for accuracy.
- Refer to your vehicle service manual for the specified maximum and minimum amounts of backlash.

#### **IMPORTANT:**

**It is critical to set up bearing pre-load when a differential is installed. Improper pre-load will result in undue bearing wear, increased stresses in the differential center, increased running noise, and ultimately, ring and pinion gear damage.**

- Adjust the backlash and pre-load using the supplied hex tool and appropriate socket to tighten or loosen the adjuster nuts as required. (Refer to your vehicle service manual.)
- Recheck backlash as before, repeating this procedure until backlash is within the specified amount.
- Tighten the bearing cap bolts with a torque wrench to the torque specified in your vehicle manufacturer's service manual.

**Figure 11.**

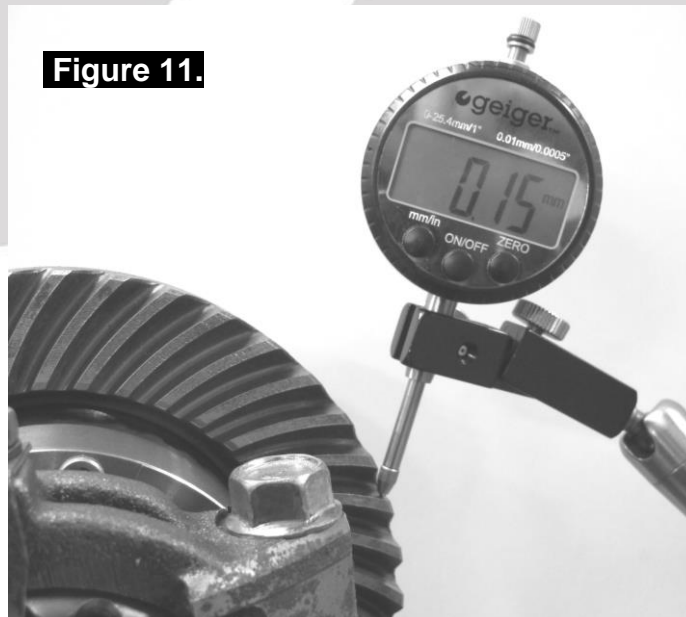

### 3 Installing the Air Locker

#### 3.9 Setting up the Bulkhead Fitting

- Apply thread sealant to the outside threads of the bulkhead body.
- Screw the bulkhead body into the tapped hole, and lightly tighten using a 14mm [9/16"] spanner.
- Wipe the area clean of any excess thread sealant (inside and outside of the housing).
- Without using sharp, jagged tools such as pliers (your hands are the best tool for this job), bend the seal housing tube on the outside of the housing to approximate the finished profile. This will allow the tube to be trimmed to a length that would allow it to protrude from the bulkhead fitting. (See Fig. 12.).

**NOTE :** Use an automotive brake line tubing cutter to cut the seal housing tube, never a hacksaw as this will leave metal filings in the air system.

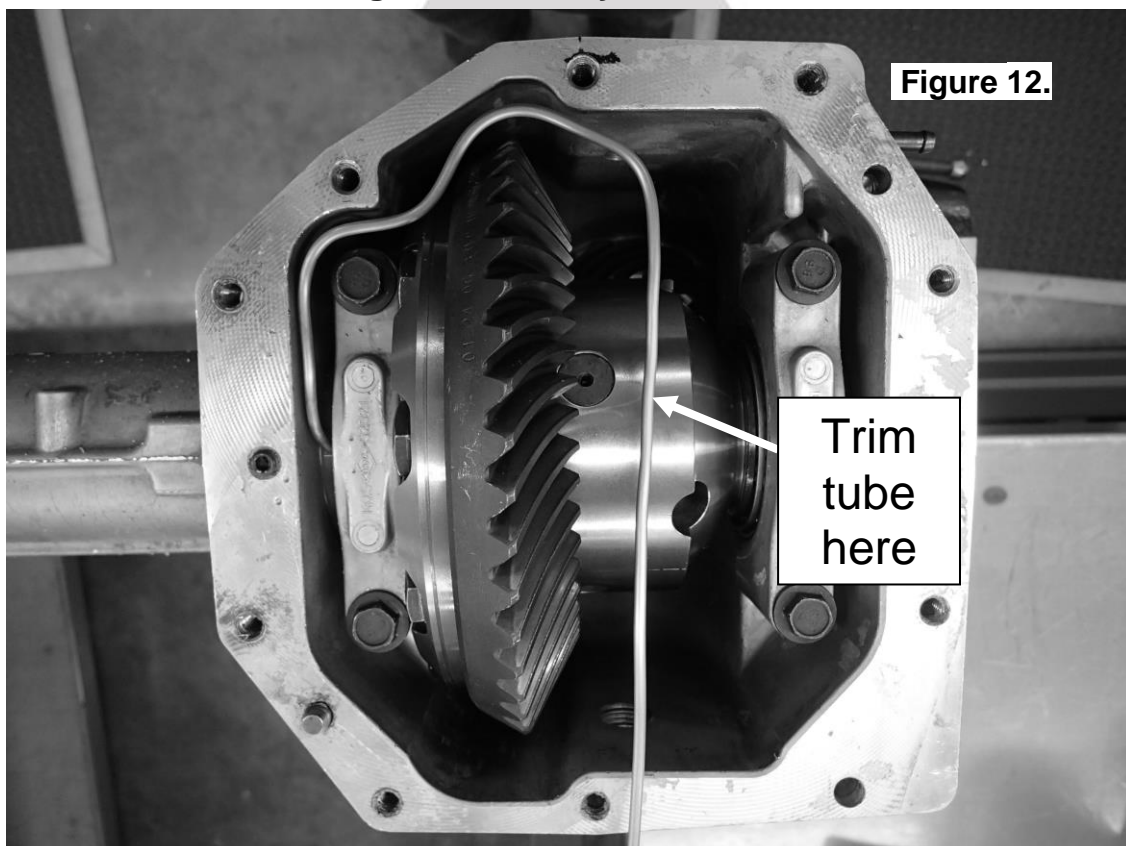

- Insert the free end of the seal housing tube into the bulkhead fitting until it protrudes approximately 8mm [5/16"] through the other side.
- From the outside of the housing, assemble one of the small O-rings over the top of the short length of seal housing tube protruding through the bulkhead fitting.

### 3 Installing the Air Locker

- Install the brass spacer.
- Install the second small O-ring after the spacer.
- While holding the seal housing tube into the bulkhead fitting, insert the chamfered end of the center compression nut over the extended tube as shown in the assembly diagram (Fig. 13.), and screw it into the bulkhead body, and tighten using Pozidriv #3 screwdriver.

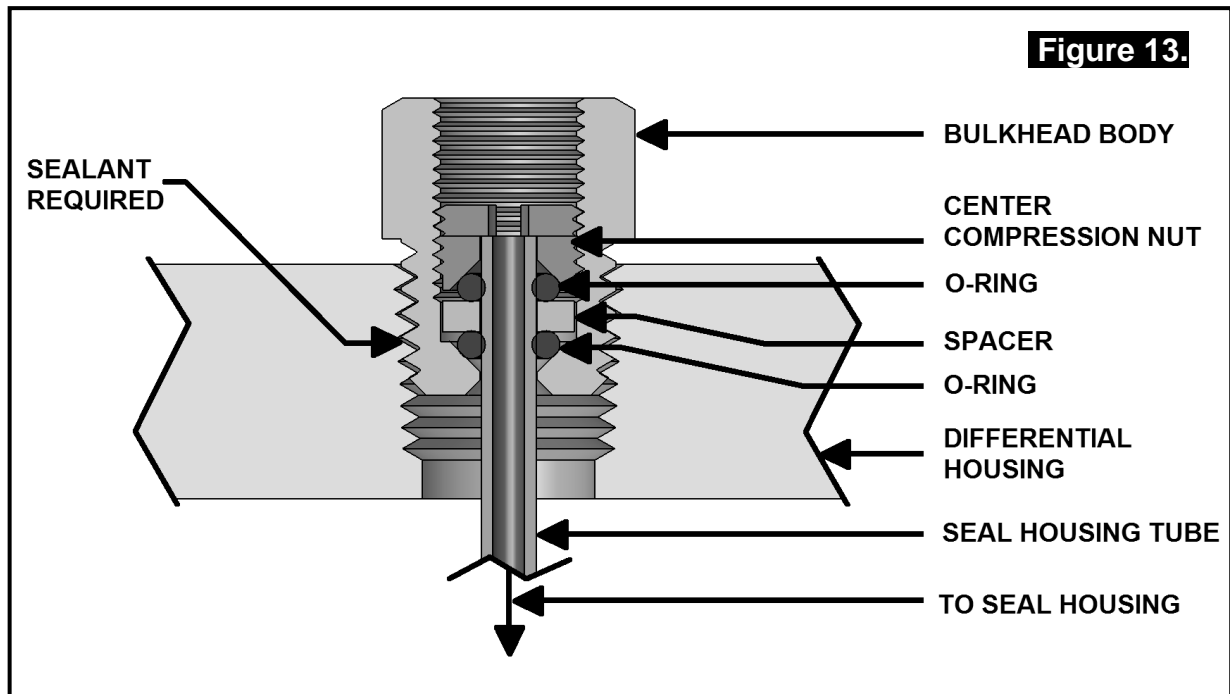

**NOTE :** Make sure the seal housing tube is all of the way into the center compression nut while you are tightening it.

**NOTE :** Firmly tighten the center compression nut so that a good seal is formed around the tube.

### 3 Installing the Air Locker

#### 3.10 Profiling the Seal Housing Tube

- With the seal housing tube now firmly secured into the bulkhead fitting, bend the tube so that it closely follows the profile shown in Fig.14.
- Check that the contour of the tube will not interfere with the bearing caps, the *Air Locker* or the ring gear.

Figure 14.

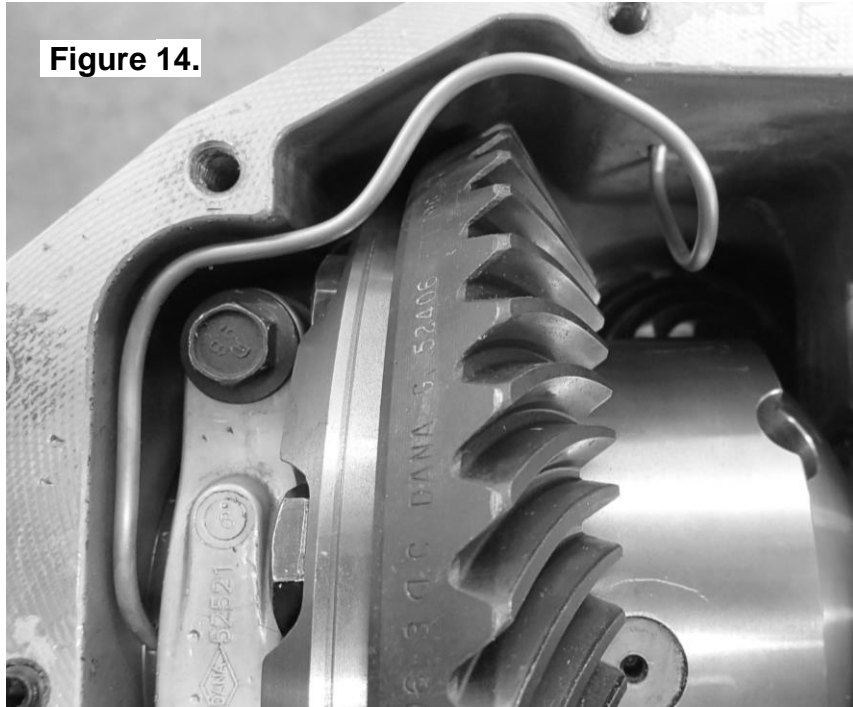



## 3 Installing the Air Locker

### 3.11 Bench Testing the Air Locker

- To test the *Air Locker*, when 620kPa [90 PSI] shop air is applied to the seal housing tube, the *Air Locker* should engage.
- Check all fittings and the seal housing for air leaks.
- Rotate the differential carrier by turning the pinion flange whilst applying air pressure.

**NOTE :** An accurate way to test for air leaks is to fit a shut-off valve to an air pressure gauge (ARB part #0770005). Once 620kPa (90psi) is reached, close the valve, disconnect the air hose and watch to see if there is any drop in pressure. If so, this will indicate an air leak. (Fig.15.)



- If a leak is found to be present, spray a soap and water mixture onto the bulkhead air fitting. Bubbles should appear at any leak points.

**NOTE :** Do not spray this soapy mixture inside the differential.

- Check that leaky fittings have been adequately tightened.
- Disassemble, clean threads, and reapply thread sealant if leaking persists.
- If a leak is found at the seal housing, carefully remove the seal housing assembly and examine the O-rings. Be very careful with the O-rings and check for defects, damage, wear or presence of foreign material in the O-ring grooves. Replace if necessary.

## 3 Installing the Air Locker

### 3.12 Reinstalling Differential and Axles

- Reassemble the differential assembly according to your vehicle manufacturer's service manual using gasket sealant where necessary.
- When inserting the axle shafts into the differential housing a gentle tap will be required to seat the retaining clips.

**NOTE :** Be careful not to damage oil seals with the axles.

- Install the differential assembly into the vehicle.

**HINT :** Clearance around the bulkhead fitting once the differential is installed is very tight. Connect the airline onto the bulkhead fitting (see section 4.3) before lifting the differential back into the vehicle.

- Reconnect the axle shaft flanges and the drive shaft flange.

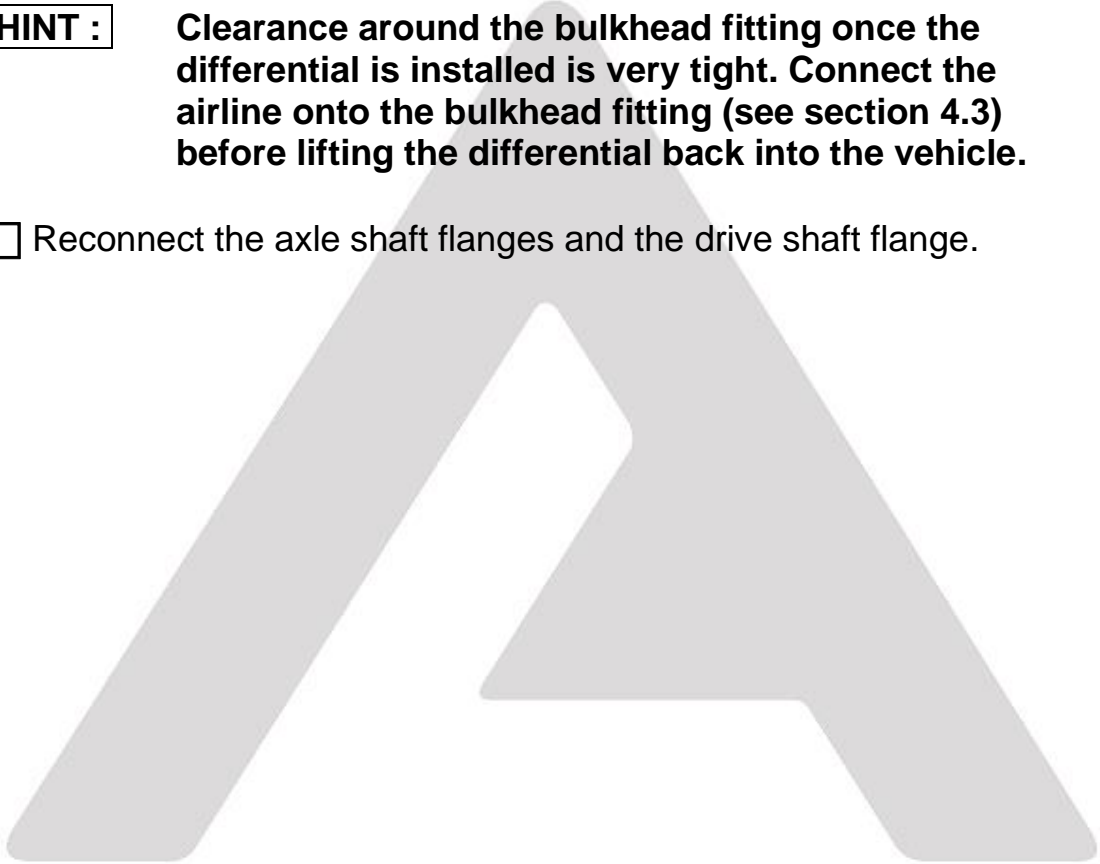



## 4 Installing the Air System

### 4.1 Mounting the Solenoid

#### 4.1.1 Connection to an ARB Air Compressor (Fig.16.)

- Remove one of the 1/8" BSP plugs from its port in the compressor tank.
- Apply Teflon paste to the 1/8" BSP nipple on the solenoid and insert it into the port and tighten. The solenoid should be rotated into a position which does not obstruct any other ports on the compressor tank.

**NOTE :** The coil and stem of the solenoid can be removed to make installation easier.

**NOTE :** The solenoid is marked with two #1 ports. If space is tight, a second solenoid can be "daisy-chained" off the first one by removing the plug from the redundant #1 port and screwing the nipple from the second solenoid into it (Fig. 16.).

**NOTE :** The solenoid exhausts compressed air through the center of the black retaining cap when the *Air Locker* is disengaged. Make sure this orifice cannot be obstructed.

- Assemble the 6mm push-in fitting into the solenoid outlet port (stamped "2") and hand tighten.

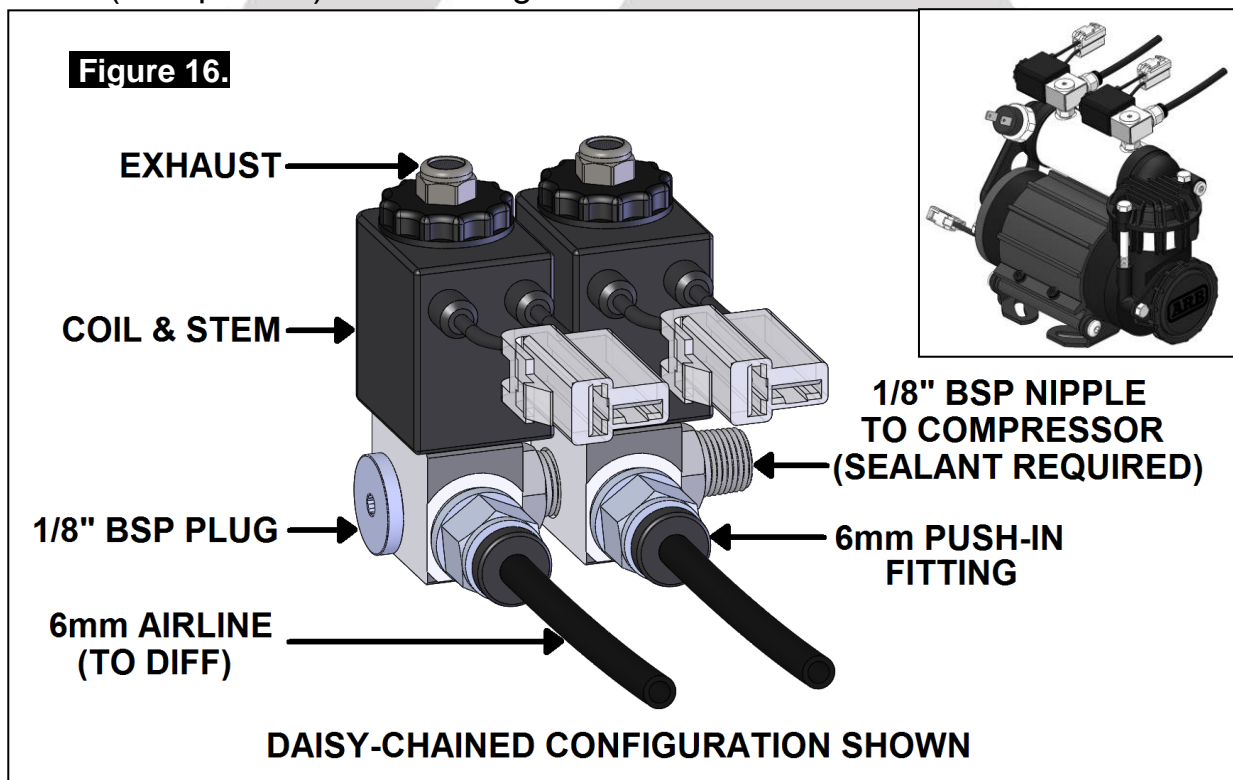

## 4 Installing the Air System

### 4.1.2 Connection to an Alternate Air Source

---

For ease of installation, quality of air supply, and a high level of dependability from your *Air Locker(s)*, ARB strongly recommends use of a genuine ARB Air Compressor, however, the *Air Locker* air system can be operated on any alternate air source that meets each of the following guidelines:

- Must supply a minimum of 586 kPa [85 PSI].
- The air source should have a tank capacity which enables it to actuate the *Air Locker(s)* in one charge so that no hesitation is experienced when locking one or two differentials.

**HINT :** A good way to insure that you have the necessary capacity is to make sure you can engage, disengage, and then reengage your *Air Locker(s)* without the air source having to regenerate (e.g., without the compressor turning on to refill the tank).

- Must supply clean air, free of rust, dirt, water, or other foreign matter.
- Must match the 1/8" BSP porting of the *Air Locker* solenoid.
- Mount solenoid within close proximity of the air supply and secure it from the effects of vibration and shock.
- Connect the air supply to the 1/8" BSP inlet port of the solenoid (stamped "1" on the solenoid body) using thread sealant.

#### **IMPORTANT :**

**ARB cannot warrant your *Air Locker(s)* against damage caused as a result of using an alternate air supply. If you have any doubts as to the suitability of your air system to use in an *Air Locker* system, consult your ARB distributor.**

## 4 Installing the Air System

### 4.2 Running and Securing the Air Line

The path taken by the air line from your air source (i.e., compressor) to your *Air Locker* is unique to your vehicle and the position of your air source. Plan ahead carefully when running the air line and always follow these guidelines:

- Account for axle travel when running the line from the axle to a fixed point on the vehicle. Leave enough slack in the air line to allow for maximum suspension travel in both directions.
- Avoid leaving large lengths of air line hanging underneath the vehicle where they may get tangled on rocks, sticks, etc.

**HINT :** **Cable tying the air line to one of your flexible brake lines will account for axle travel and should help keep your line from getting snagged.**

- Run the air line all the way from the compressor to the differential before trimming either end of the line to length. This will save complications that may arise if the air line has to be removed.
- Make sure the line does not contact sharp edges or abrasive surfaces that may damage the air line over time.
- Do not run the air line around tight bends that may kink the air line and restrict or block the air flow.
- Keep the air line well away from your vehicle's exhaust components. Air lines will melt if subjected to extreme heat.
- Do not run more air line than necessary. Excess line volume created when coiling the left over hose, using unusually large diameter hose, etc., will increase drain on the compressor tank resulting in the compressor running more often than needed.
- Support the air line by tying it back with cable ties wherever possible.
- At the solenoid end of the air line, trim the line to length with a sharp knife.
- To attach the air line to the push-in fitting of the solenoid; insert the line firmly into the fitting, pull outward on the flange of the fitting while holding the line as far into the fitting as possible, and then gently pull outward on the air line to clamp the line in place.

## 4 Installing the Air System

**NOTE :** To remove the air line from the push-in fitting; push the air line as far into the fitting as possible and hold, push inward on the flange, and then pull the air line free of the fitting.

### 4.3 Connection to the Bulkhead Fitting

- Trim the air line to length using a sharp knife.
- Assemble an aluminium washer onto the banjo bolt and insert through the banjo fitting. Assemble second aluminium washer and tighten into bulkhead fitting using a 14mm [9/16"] spanner. (Fig.17.)
- Apply thread sealant to the tapered thread of the compression fitting body and screw into the banjo fitting. Tighten using a 12mm spanner.
- Insert the outer compression nut and ferrule over the air line. Ferrule should be orientated as per Fig.17.

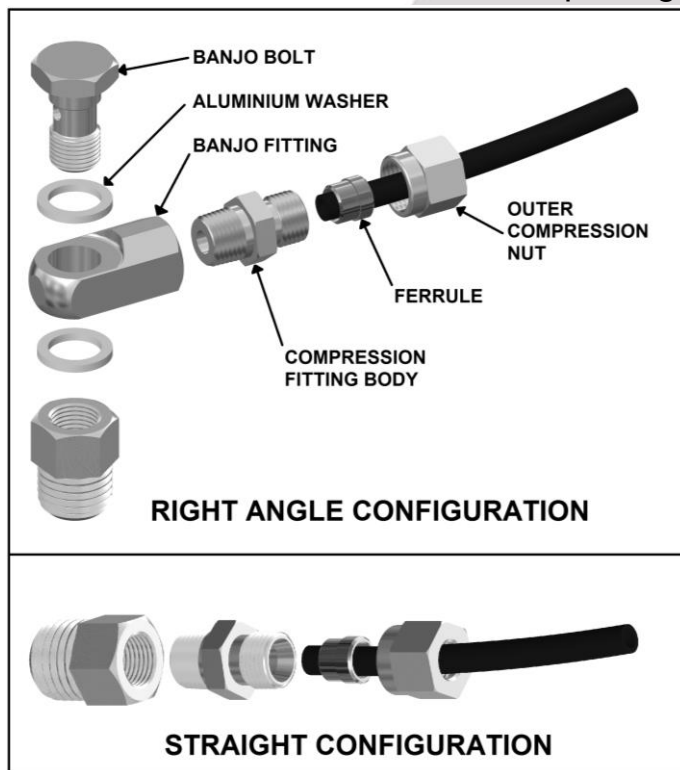

## 4 Installing the Air System

- Push the airline into the compression fitting body and screw the outer nut down onto it. Using a 12mm spanner, tighten the outer nut onto the compression fitting body.

**NOTE :** Some force is required to crush the ferrule, however the outer compression nut will tighten against a stop. Over tightening will not create a better seal.

- Secure any loose sections of tube with a cable tie.

**NOTE :** When right angle routing of the tube is not required, screw the compression fitting body straight into the bulkhead fitting body (Fig.17.).

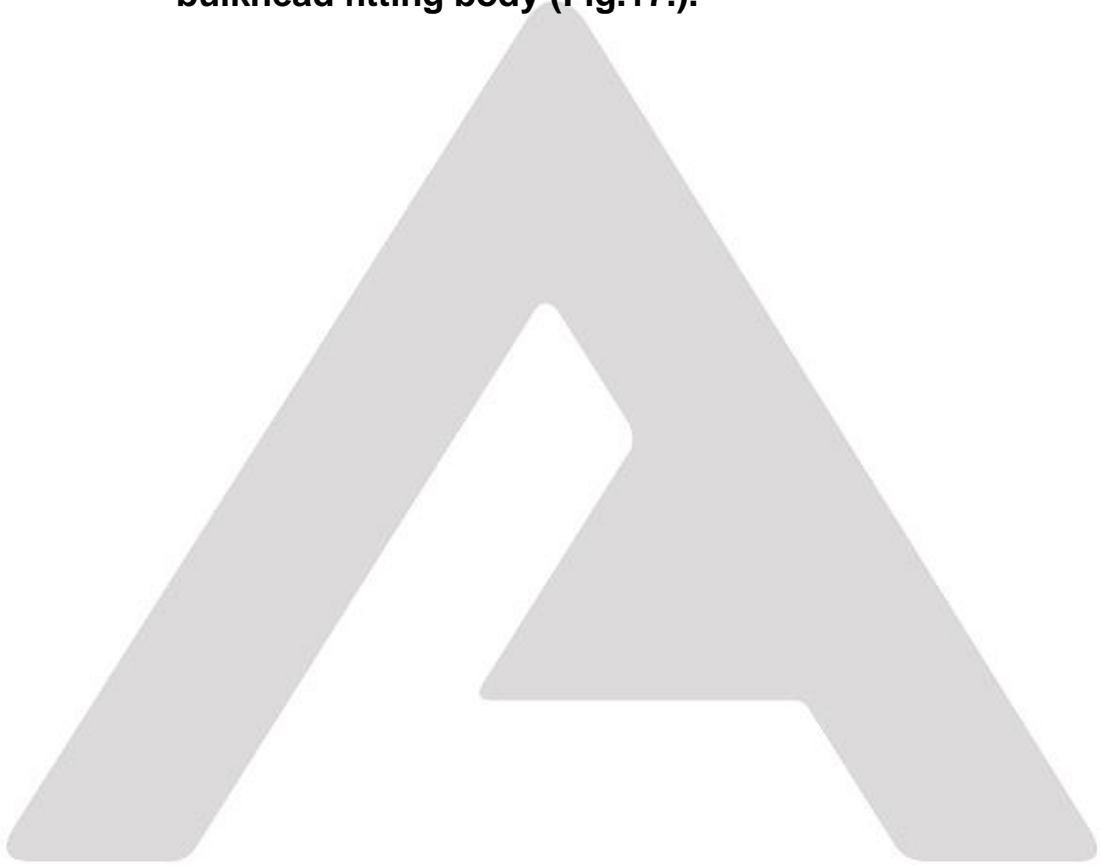

## 5 Mounting & Connecting the Electrical System

### 5.1 Mounting the Actuator Switch(es)

*Air Locker* actuator switch(es) can be easily panel mounted inside the vehicle in a 21mm x 36.5mm [0.83" x 1.44"] rectangular cutout.

**NOTE :** Only attach the cover plate to the face of the switch once the switch has been mounted and wired correctly as the cover plates are designed to be difficult to remove.

For reasons of safety and for ease of operation, the *Air Locker* actuator switch(es) should be mounted in a location picked to best suit the operator. Make sure you have taken the following points into consideration:

- Switch(es) MUST be mounted and should never be allowed to simply dangle from the wiring loom during vehicle use.
- Switch(es) should be within easy reach of the driver. Ideally, any *Air Locker* switch should be able to be operated without physical effort or distraction to the driver.
- Switch(es) should be mounted within the line of sight of the driver so that switch position ('ON' or 'OFF') can be visually determined by the rocker position and the illumination state.
- The position of the switch(es) should best eliminate any possibility of accidental operation by the driver or one of the passengers.
- Switch cutout position(s) must be located in an area with a minimum of 50mm [2"] of clearance behind the face of the cutout.
- Switch(es) should not be mounted where they will be exposed to water (e.g., in the lower section of an inner door panel).
- ARB recommends that you apply the *Air Locker* Warning Sticker (ARB part # 210101) within close visual proximity of the switch location.

**NOTE :** If no adequate position can be found on existing dashboard panels, a surface mounted bracket (Fig. 18.) may be purchased from your ARB *Air Locker* distributor to suit 1, 2, or 3 switches.



**Figure 18.**



# 5 Mounting & Connecting the Electrical System

## 5.2 Wiring the Actuator System

### 5.2.1 Connection to an ARB AIR COMPRESSOR

When wiring the *Air Locker* actuator switch(es) and solenoid(s) to an ARB Air Compressor, all connections can easily be set up directly from the supplied wiring loom. (Fig.19.)

**NOTE :** 180409 model loom shown for reference only. Refer to your ARB Air Compressor Installation Guide for details on configuring your installation.

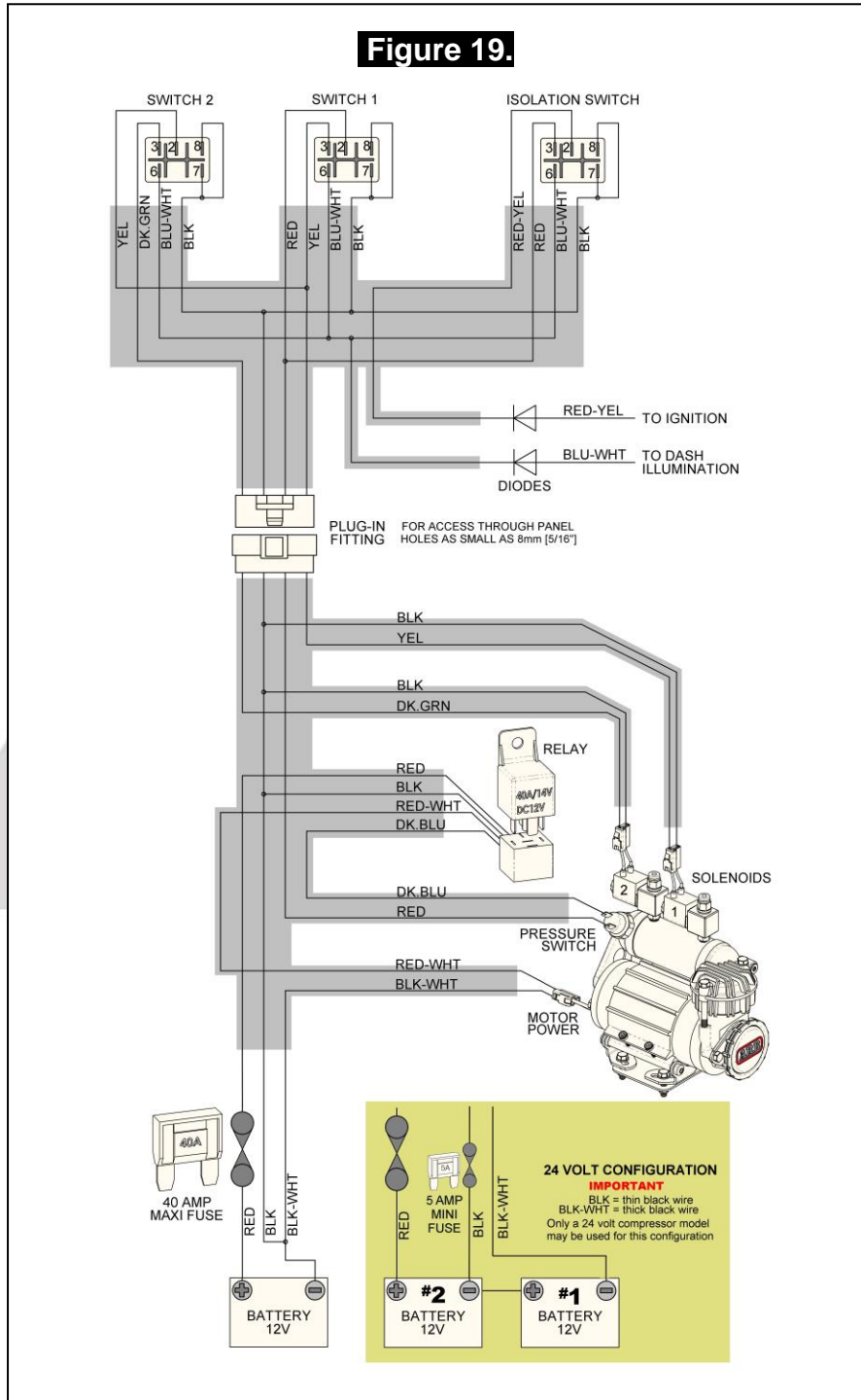

## 5 Mounting & Connecting the Electrical System

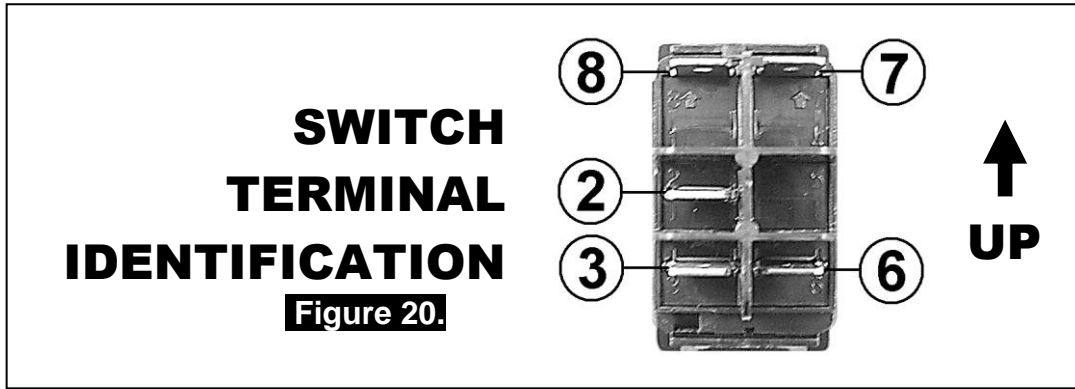

### 5.2.2 Connection to an Alternate Air Source

When connecting the actuation switch to an alternate air source, the switch(es) should be wired according to figures 21. and 22. depending on whether one or two *Air Lockers* will be installed in the vehicle.

#### 5.2.2.1 Single Air Locker System

- If only one *Air Locker* is to be installed in the system, the switch and solenoid should be wired according to figure 21. regardless of whether the *Air Locker* has been installed in the front or rear axle of the vehicle.
- Attach the appropriate switch cover (i.e., 'FRONT' or 'REAR') to the switch.

**NOTE :** Refer to figure 20. for the correct switch terminal identification and switch orientation.

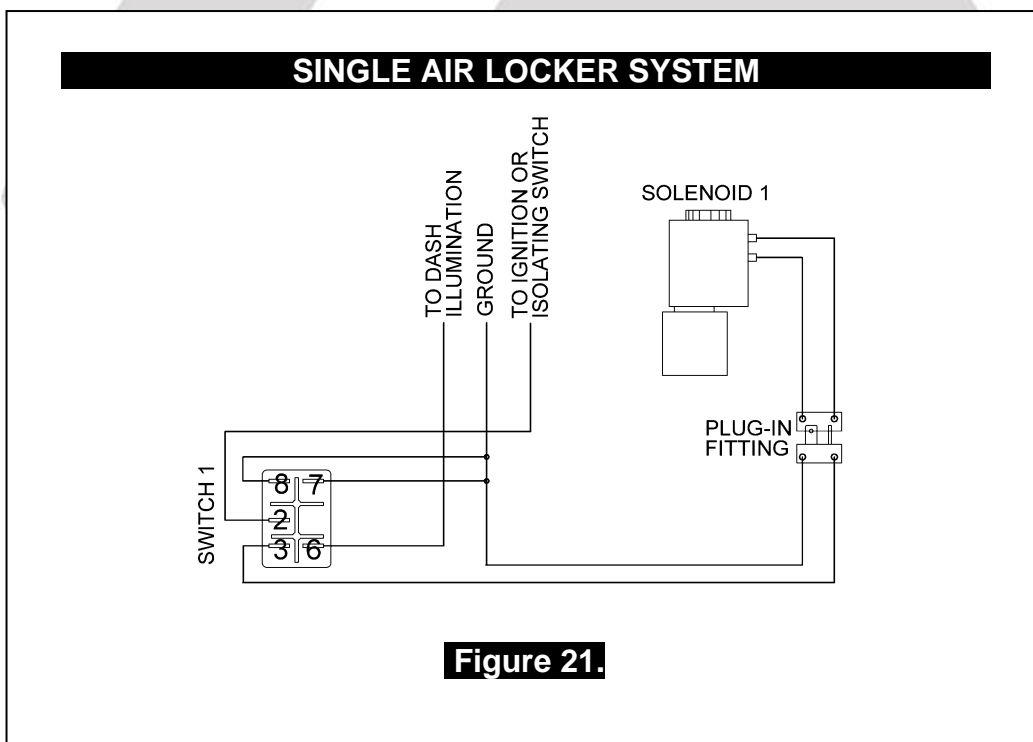



## 5 Mounting & Connecting the Electrical System

### 5.2.2.2 Dual Air Locker System

- If two *Air Lockers* are to be installed in the system, ARB recommends that the switches and solenoids be wired according to figure 22. For safety reasons, this configuration allows SOLENOID 2 to be actuated only if SOLENOID 1 is already on.
- Attach the “REAR AIR LOCKER” switch cover to SWITCH 1, and the “FRONT AIR LOCKER” switch cover to SWITCH 2.

**NOTE :** Refer to figure 20. for the correct switch terminal identification and switch orientation.

- Configure SOLENOID 1 as the air line leading to the rear axle *Air Locker*, and SOLENOID 2 as the air line leading to the front axle *Air Locker*.

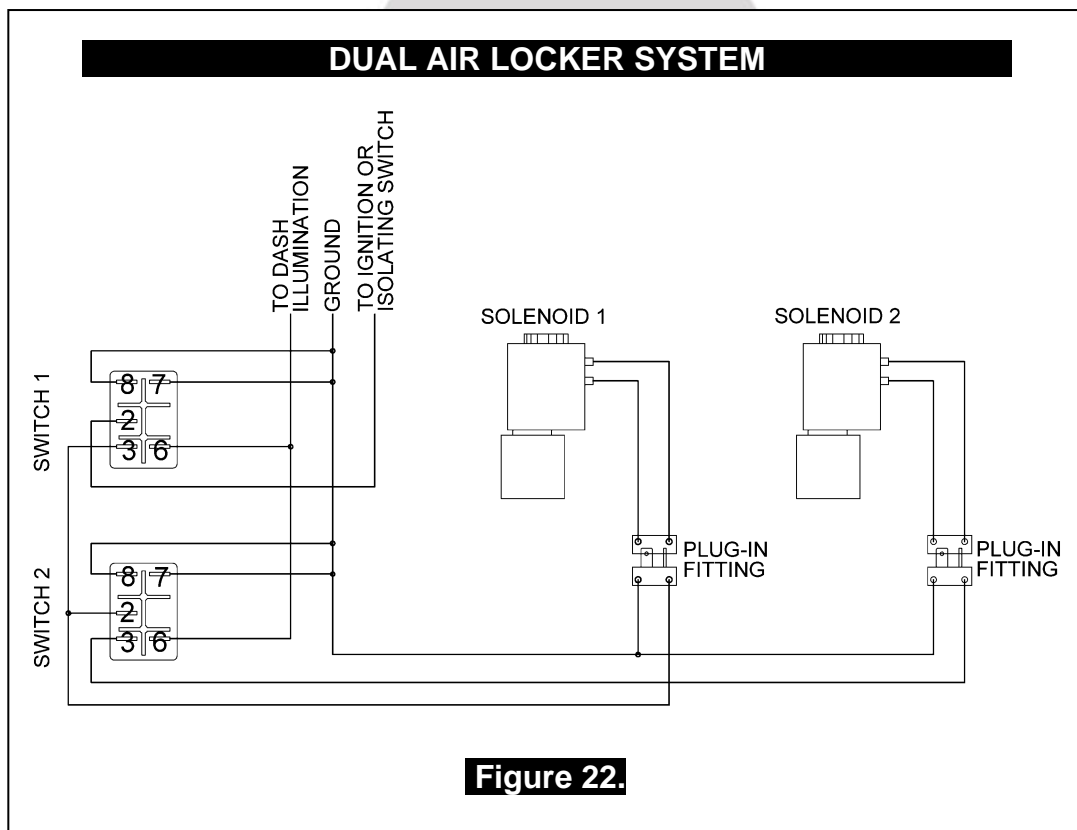

## 6 Testing & Final Assembly

### 6.1 Leak Testing

- With the vehicle parked and the engine off, turn the compressor on and wait until the air system is fully charged.

**NOTE :** With the *Air Locker(s)* disengaged, the air source (i.e., compressor) should not have to recharge over time. Intermittent recharging without *Air Locker* use usually indicates a leak at the solenoid fittings or at the compressor tank O-ring seal.

- Actuate the *Air Locker(s)*.
- The compressor should not come on again for a period of at least 15min. Air system recharging within that time period would indicate that a leak is present in the system.

**NOTE :** If an alternate air source (e.g., an air cylinder or a belt driven air pump) is used instead of a compressor, the air system will have to be leak tested with a pressure gauge and a shut-off valve in series before the solenoid input. (Fig.15.)

- If a leak is found to be present, spray a soap and water mixture onto all air fittings in the system while the compressor is fully charged. Bubbles should appear at any leak points.
- Check that leaky fittings have been adequately tightened.
- Disassemble, clean threads, and reapply thread sealant if leaking persists.

### 6.2 Testing the Air Locker Actuation

To test that your air system, electrical system, and your *Air Locker* differential is functioning correctly:

- Support the vehicle such that the wheels are free to rotate (e.g., on axle stands, a chassis hoist, etc.)
- Leave the parking brake off, the transmission in neutral, and the *Air Locker* switch 'OFF'.
- Turn the ignition to the 'ON' position (leaving the motor off). The large illuminating symbol on the *Air Locker* switch cover should be 'OFF'.

## 6 Testing & Final Assembly

- Turn the compressor (or alternate air source) on to charge the air supply up to its maximum pressure.
- Rotate one wheel by hand.
- The wheel should rotate freely and the opposite wheel should be turning in the opposite direction without any resistance or mechanical noise from within the differential.
- Turn the *Air Locker* switch to the 'ON' position. The illuminated symbol on the switch cover should light up.
- Rotate the same wheel again.
- Both wheels should rotate together.
- Turn the switch off again.
- Rotate the same wheel.
- The wheels should again rotate in opposite directions.

### 6.3 Filling the Differential

**NOTE :** Consult the *ARB Air Locker Operating & Service Manual* for recommendations on differential lubricant specifications.

- Refill the differential until level with the filler hole.
- Rotate the differential center 2 full turns.
- Check the oil level and add oil if necessary.
- Apply thread sealant to filler plug before inserting.
- Replace the filler plug.
- Clean the differential housing of any oil or grease that may collect dirt or other abrasive particles.

## 6 Testing & Final Assembly

### 6.4 Post-Installation Check List

Now that the *Air Locker* installation has been completed, ARB recommends that you take the time to complete the following check list just to insure that you haven't missed any of the vital steps.

- The air system has been leak tested.
- Thread locking compound was used on the ring gear bolts.
- All torque settings comply with the vehicle manufacturer's specs and were set with an accurate torque wrench.
- Differential fluid complies with ARB recommendations and has been filled to the correct level.
- All air lines and wiring have been securely cable tied to resist snagging.
- Switch(es) have been securely mounted within operator reach, yet well away from danger of accidental engagement.
- Switch(es) function properly and illuminate to indicate *that Air Locker(s)* are engaged.
- All operators who are to use the *Air Locker* have read, and fully understand the *ARB Air Locker Operating & Service Manual*.
- The *Air Locker* Warning Sticker has been located within close proximity of the actuator switch(es).

INSTALLATION PERFORMED BY: \_\_\_\_\_

DATE OF INSTALLATION: \_\_\_\_\_

ODOMETER READING: \_\_\_\_\_

ARB AIR LOCKER SERIAL No.: \_\_\_\_\_



## 7 Parts List

**RD224**

Nissan M205, FR, 30 SPL

### 7.1 Exploded Assembly Diagram

(See itemized parts list overleaf)

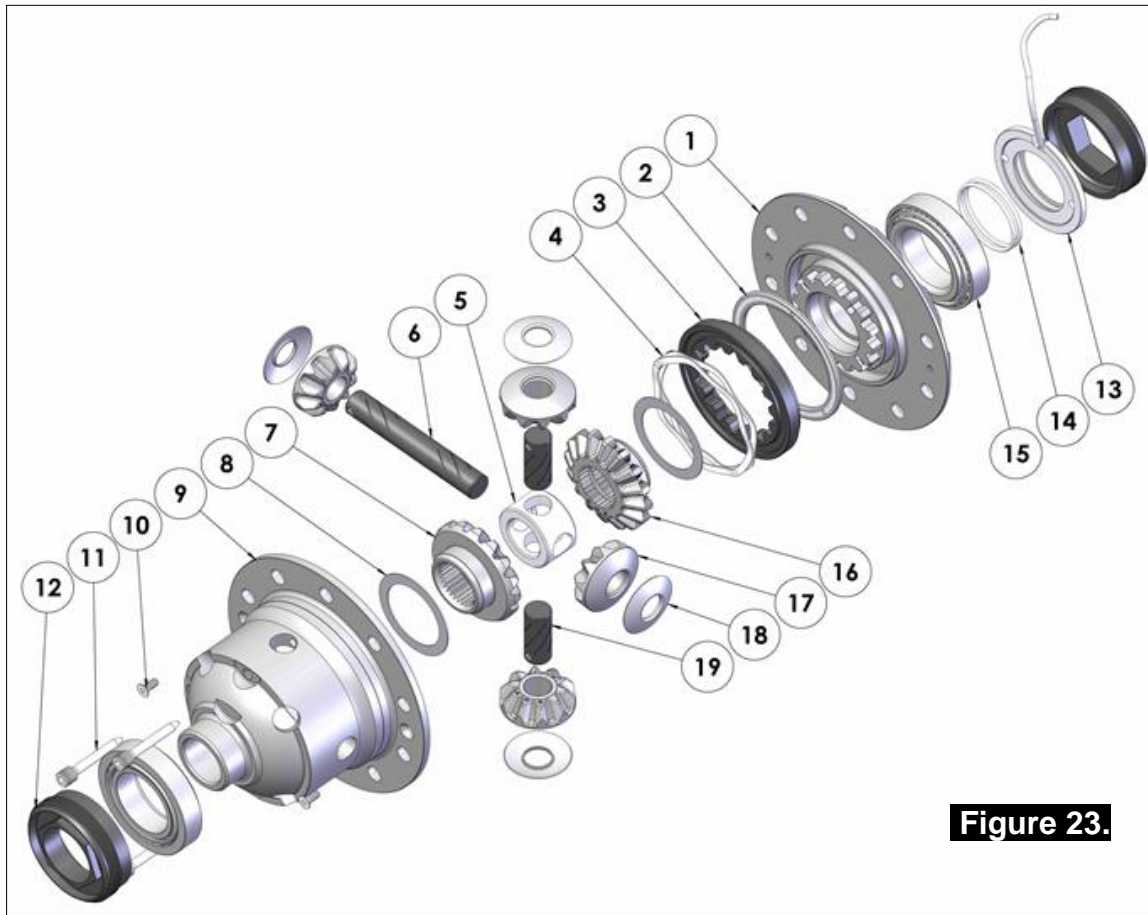

**Figure 23.**

### 7.2 Specifications

Axle Spline	30 tooth, Ø32.8mm [1.29"]
Ratio Supported	All
Ring Gear ID	121.26mm [4.77"]
Ring Gear OD	205mm [8.07"]
Ring Gear Bolts	10 bolts on Ø146.1mm [5.75"]
Ring Gear Torque	145Nm [107 ft-lb]
Backlash	0.13-0.18mm [0.005-0.007"]
Bearing Cap Torque	51Nm [38ft-lb]

## 7 Parts List

### 7.3 Itemized Parts List

(See exploded diagram Figure 23.)

ITEM #	QTY	DESCRIPTION	PART #	NOTES
01	1	FLANGE CAP KIT	028524SP	
02	1	BONDED SEAL	160701SP	
03	1	CLUTCH GEAR & WAVESPRING KIT	050902SP	
04	1	WAVESPRING	150702SP	
05	1	SPIDER BLOCK	070503SP	
06	1	LONG CROSS SHAFT	061302SP	
07	1	SIDE GEAR	SEE NOTE	2
08	2	SIDE GEAR THRUST WASHER	SEE NOTE	3
09	1	DIFFERENTIAL CASE	013124SP	
10	1	COUNTERSUNK SCREW (PK OF 2)	200213SP	
11	1	RETAINING PIN SET (PK OF 4)	120601SP	
12	2	OE ADJUSTER NUT	NOT SUPPLIED	
13	1	SEAL HOUSING KIT	081825SP	
14	1	SEAL HOUSING O-RINGS (PK OF 2)	160235-2	1
15	2	TAPERED ROLLER BEARING	NOT SUPPLIED	
16	1	SPLINED SIDE GEAR	SEE NOTE	2
17	4	PINION GEAR	SEE NOTE	2
18	4	PINION THRUST WASHER	SEE NOTE	3
19	2	SHORT CROSS SHAFT	061402SP	
*	1	BULKHEAD FITTING KIT (BANJO TYPE)	170114	4
*	1	AIR LINE (6mm DIA X 6m LONG)	170314SP	4
*	1	SOLENOID VALVE (12V)	180103	
*	1	SWITCH FR LOCKER	180223	
*	1	CABLE TIE (PK OF 25)	180305	
*	1	OPERATING & SERVICE MANUAL	210200	
*	1	INSTALLATION GUIDE	2102224	

\* *Not illustrated in exploded view*

### NOTES

- 1 For replacement O-rings use only BS136 Viton 75.
- 2 Available only as complete 6 gear set # 728J111
- 3 Available only as complete thrust washer kit #730J01
- 4 All diffs produced before serial #17070001 came with 5mm air connection system.  
For information contact ARB.

Part No. 2102224  
Revision 28/10/2020  
Copyright © 2015 by ARB Corporation Limited

