



RD90

TOYOTA 7.5", IFS

AIR OPERATED
LOCKING DIFFERENTIAL
INSTALLATION GUIDE

No liability is assumed for damages resulting in the use of the information contained herein.
ARB AIR LOCKER Locking Differentials and AIR LOCKER are trademarks of ARB Corporation Limited.
Other product names used herein are for identification purposes only and may be trademarks of their respective owners.

ARB 4x4 ACCESSORIES

Corporate Head Office

**42-44 Garden St
Kilsyth, Victoria
AUSTRALIA
3137**

**Tel: +61 (3) 9761 6622
Fax: +61 (3) 9761 6807**

**Australian enquiries
North & South American enquiries
Other international enquiries**

**sales@arb.com.au
sales@arbusa.com
exports@arb.com.au**

www.arb.com.au

Table of Contents:

1	Introduction	3
1.1	Pre-Installation Preparation	3
1.2	Tool-Kit Recommendations	4
1.3	Assembly Type Identification	5
2	Removing the Existing Differential	6
2.1	Vehicle Support	6
2.2	Differential Fluid Drain	6
2.3	Removing the Differential Assembly	6
2.4	Checking the Current Backlash Amount	8
2.5	Removing the Differential Center	10
3	Installing the Air Locker	11
3.1	Approximate Backlash Shimming	11
3.2	Calculation & Selection of Backlash Shims	13
3.3	Mounting the Ring Gear	14
3.4	Installing the Carrier Bearings	15
3.5	Preload Shim Measurement	16
3.6	Calculation & Selection of Preload Shims	18
3.7	Drilling & Tapping the Bulkhead Port	19
3.8	Installing the Bulkhead Fitting	21
3.9	Installing the Differential Center	21
3.10	Setting Up the Bulkhead Fitting	24
3.11	Final Assembly	25
3.12	Checking the Backlash	27
3.13	Bench Testing the Air Locker	30
3.14	Reinstalling the Differential Assembly	31
4	Installing the Air System	32
4.1	Mounting the Solenoid	32
4.2	Running & Securing the Air Line	34
4.3	Connection to the Bulkhead Fitting	35
5	Mounting & Connecting the Electrical System	36
5.1	Mounting the Actuator Switch(es)	36
5.2	Wiring the Actuator System	37
6	Testing & Final Assembly	40
6.1	Leak Testing	40
6.2	Testing the Air Locker Actuation	40
6.3	Re-Sealing & Filling the Differential	41
6.4	Note For ADD Equipped Vehicles	41
6.5	Post-Installation Check List	42
7	Parts List	43
7.1	Exploded Assembly Diagram	43
7.2	Specifications	43
7.3	Itemized Parts List	44



1 Introduction

IMPORTANT :

BEFORE ATTEMPTING TO DISMANTLE YOUR VEHICLE FOR THIS INSTALLATION, PLEASE READ THIS INSTALLATION GUIDE IN ITS ENTIRETY, AS WELL AS ALL APPLICABLE SECTIONS OF YOUR VEHICLE MANUFACTURER'S SERVICE MANUAL.

1.1 Pre-Installation Preparation

This booklet is to be used in conjunction with your vehicle manufacturer's service manual. ARB endeavors to account for every possible variation in vehicle model when publishing its installation guides, and guides are updated regularly as new model information becomes available, however, the rapid and globally varied release of some vehicles makes it difficult to insure that your vehicle model has been accurately accounted for. In the case of any technical discrepancies between this guide and your service manual, we strongly advise that you adhere to the specifications and techniques as documented in your service manual.

Although your *ARB Air Locker* comes complete with all the step by step instructions you will need to supplement your vehicle manufacturer's service manual and install your new differential, ARB recommends that you have your *Air Locker* installed by a trained professional. Many ARB distributors around the world have been fully instructed in *Air Locker* installations by ARB, and have gained a wealth of experience and skill from years of performing similar installations.

Once you begin this installation your vehicle will be immobile until all steps of the installation are complete. Make sure your *Air Locker* kit is the correct model for your vehicle and that it contains all of the parts listed on back cover of this booklet. Also be sure you have appropriately equipped yourself with all the necessary tools, parts, and materials to complete this installation (see Section 1.2 *Tool-Kit Recommendations*), and that you have allowed for an appropriate amount of vehicle down time.

HINT :

Place a ✓ mark inside each of the symbols as you complete each step. It is very important NOT to miss any of the steps!

1 Introduction

1.2 Tool-Kit Recommendations

Below is a list of tools and supplies you may need to complete this installation. Requirements for your vehicle may vary. Please consult your vehicle service manual for additional recommendations.

1.2.1 Tools

- Standard automotive sizes (metric and/or imperial) of sockets, wrenches, Allan keys, and drills.
- A dial indicator or other suitable measuring tool for checking ring & pinion backlash.

NOTE : Split 'clamshell' type Toyota differential housings require a long series dial indicator to check backlash. Refer to Section 1.3 *Vehicle Type Identification*.

- A razor knife for nylon tubing.
- A torque wrench (See vehicle service manual for required torque range)
- A lubricant drain reservoir.
- A slide hammer for removing CV axles.
- Suitable measuring tools to measure a differential for preload shimming. (e.g., an automotive feeler gauge)
- A 11.2mm [7/16"] drill and 1/4"NPT tap for bulkhead fitting installation.
- An automotive bearing puller (2 jawed) or a differential carrier bearing puller.
- A bearing press or arbor press.

1.2.2 Supplies

- Thread lubricant/sealant compound (e.g., LOCTITE #567)
- Thread locking compound (e.g., LOCTITE #272)
- A gasket sealant or replacement gasket for your differential.
- A sufficient volume of differential oil to completely refill your housing. (see the *ARB Air Locker Operating and Service Manual* for recommended lubricants)
- A soap and water mixture to test for air leaks.
- Teflon paste.
- A selection of differential bearing shims to set-up preload and backlash.

1 Introduction

1.3 Assembly Type Identification

IMPORTANT:

Sections 2 and 3 of this installation guide have been written to accommodate two different styles of Toyota IFS differential housings:

- A** the front accessed type with bearing caps (Refer to Fig.1.)
- B** the 'clamshell' type split housing (Refer to Fig.2.)

To eliminate confusion, you should identify which figure your vehicle matches with. The section numbers within the guide that refer to the front accessed type have been suffixed with an '**A**', and those that refer to the 'clamshell' type have been suffixed with a '**B**'.

PLEASE IGNORE ALL SECTIONS WHICH DO NOT APPLY TO YOUR APPLICATION

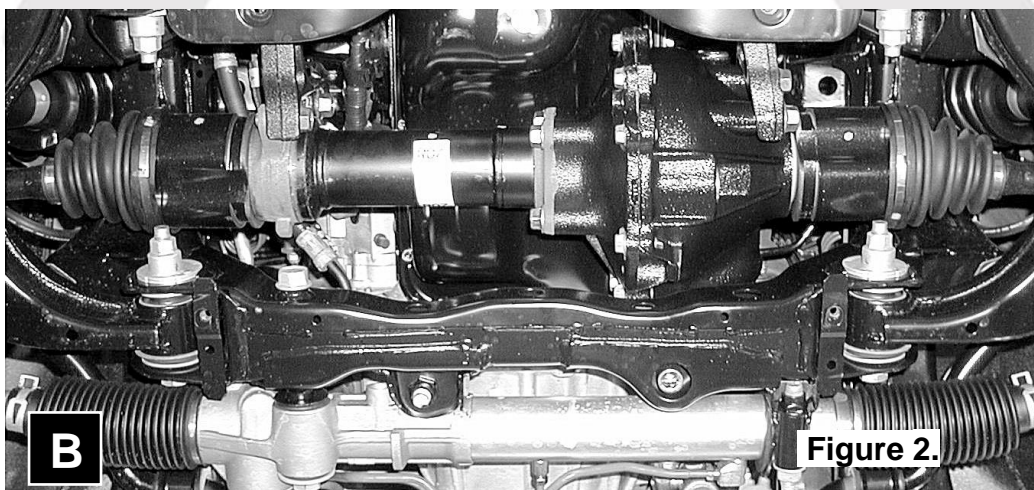
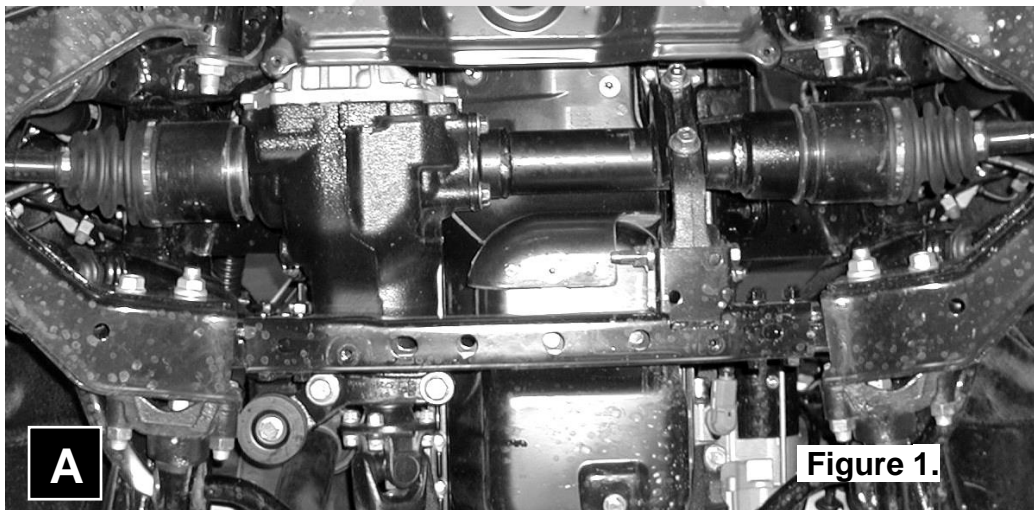

2 Removing the Existing Differential

2.1 A B Vehicle Support

- Safely secure the vehicle on a hoist. We recommend supporting the vehicle on a chassis hoist to keep the differential area at a convenient working height and to leave the wheels and axles free to be rotated and removed.
- Once supported in the air, chock the wheels (if necessary) and leave the vehicle in neutral.

2.2 A B Differential Fluid Drain

- Position a fluid drain reservoir under the differential.
- Remove the drain plug and drain all of the oil from the housing.

HINT : This is a good time to check for metal particles in your oil and on the end of the magnetic drain plug which may indicate a worn bearing or differential component.

- Once drained, reinstall the drain plug.

2.3 A B Removing the Differential Assembly

- Remove the stub axles from the differential housing according to your vehicle manufacturer's service manual.

NOTE : Rubber oil seals can be easily damaged. Support the weight of the axle when extracting it across the edges of the seals.

HINT : Some Toyota IFS axles can be removed easier by disconnecting the upper ball joint.

HINT : Toyota IFS axle stubs are retained with a snap ring which is considered to be a one-use part. Keep two of these clips on-hand in case the clip(s) are damaged or sheared off while removing the stub axle. Make sure all of the remains of the clips are accounted for so that they cannot damage differential components and seals.

- Disconnect the drive shaft from the pinion flange.
- Completely remove the entire differential assembly.

2 Removing the Existing Differential

2.3.1 A Marking the Bearing Caps

- Secure the differential assembly to a work bench.
- Completely remove the front access cover.
- Using a small pointed center punch, gently mark the left bearing cap in a way which will enable you to know which cap is 'LEFT' and 'RIGHT', and which way is 'UP' and 'DOWN'. (Fig.3.)
- Mark the right hand cap in a similar way.



HINT : Many installers choose to make one punch mark on the left hand side of the left hand bearing cap and a similar mark on the housing at close proximity to the cap mark. The right hand side is then designated with two punch marks on the right hand side of the cap and two similar punch marks on the housing.

2 Removing the Existing Differential

2.4 **A B** Checking the Current Backlash Amount

IMPORTANT:

This step is a precautionary measure recommended by ARB due to the fact that some aftermarket ring and pinion sets have been manufactured to run with different backlash settings than those specified by your vehicle manufacturer. Although ARB must recommend you set backlash according to your service manual guidelines, we also advise that you compare the backlash measurements taken here to the recommended backlash settings in your vehicle service manual. Measurements found to be outside of your service manual recommendations may indicate the need to deviate from those settings in order to achieve quiet running with a good contact mark.

Refer to your vehicle service manual or your local authorized ARB installer for more information.

2.4.1 **A** Backlash for Front Access Housing

- Set a plunge type dial indicator on one of the ring gear teeth as in Figure 4.

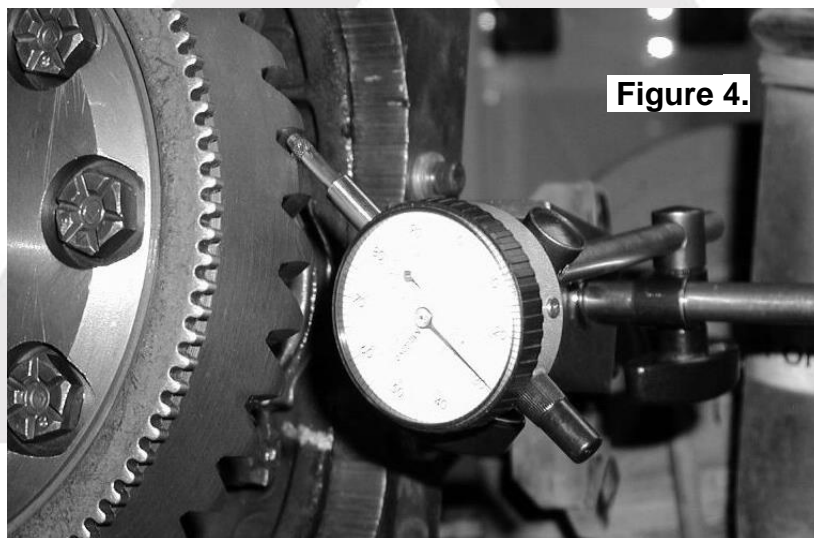

Figure 4.

- While supporting the pinion gear by holding the drive shaft flange, rotate the differential in both directions while observing the maximum variation in depth from the indicator (i.e., the highest value minus the lowest value). This value is referred to as the ring and pinion backlash.
- Rotate the differential center 90° and measure again for accuracy.
- Record the average of all measurements.

2 Removing the Existing Differential

2.4.2 B Backlash for Clamshell Housing

- Set a long series lever type dial indicator on one of the ring gear teeth. Access to the ring gear teeth is gained through the oil filler hole. (Refer to Figure 5.)



- Insert a large flat screwdriver or pry-bar through one of the axle stub holes so that it wedges between the cross shaft and the carrier body so that the differential center can be rotated by the cross shaft, and not by the spline of one of the differential gears.
- While supporting the pinion gear by holding the drive shaft flange, rotate the differential in both directions (with the screwdriver or pry-bar) while observing the maximum variation in depth from the indicator (i.e., the highest value minus the lowest value). This value is referred to as the ring and pinion backlash.
- Rotate the differential center 90° and measure again for accuracy.
- Record the average of all measurements.

2 Removing the Existing Differential

2.5 A B Removing the Differential Center

- Remove the floating shaft (or ADD unit if present) from the side of the differential housing.

NOTE : The floating shaft or stub axle is retained by the same type of clip that was used to retain the outer stub axle. A slide hammer may be required for safe removal. Refer to your vehicle manufacturer's service manual.

2.5.1 A Front Access Housing Disassembly

- Remove the bearing cap retaining bolts and then remove both bearing caps.
- Gently pry the differential center forward until it comes free of the housing.

NOTE : Be sure not to mix up the left and right hand tapered roller bearing cups or preload shims. Later it will be necessary to know which cup came from which bearing and which shim came from which side of the differential.

2.5.2 B Clamshell Housing Disassembly

- Remove all bolts from around the outside of the clamshell.
- Gently pry the clamshell apart and remove the differential center.
- Using an arbor press, remove both bearing cups and preload shims by pressing the face of the shims through the housing from the outside.

NOTE : Be sure not to mix up the left and right hand tapered roller bearing cups or preload shims. Later it will be necessary to know which cup came from which bearing and which shim came from which side of the differential.

3 Installing the Air Locker

3.1 A B Approximate Backlash Shimming

In order to reproduce a similar preload and ring and pinion backlash in your *Air Locker* to that of your existing differential, measurements need to be taken so that a shim thickness can be calculated.

- Secure the differential to a work bench.
- Remove the bolts that hold the ring gear in place.

NOTE : Ring gear bolt locking tabs used on some models will not be required on the *Air Locker* and may be discarded.

- Using a plastic or copper hammer, tap in a circle around the ring gear to separate it from the differential carrier.
- Remove the original bearings from the differential center using a bearing puller.

NOTE : Keep the bearings separated so that they can be identified as to which end of the differential they came from.

- Examine the bearing cup and cone from Figure 6. for damage or wear and, if necessary, discard it and replace it with the same size and type of bearing.

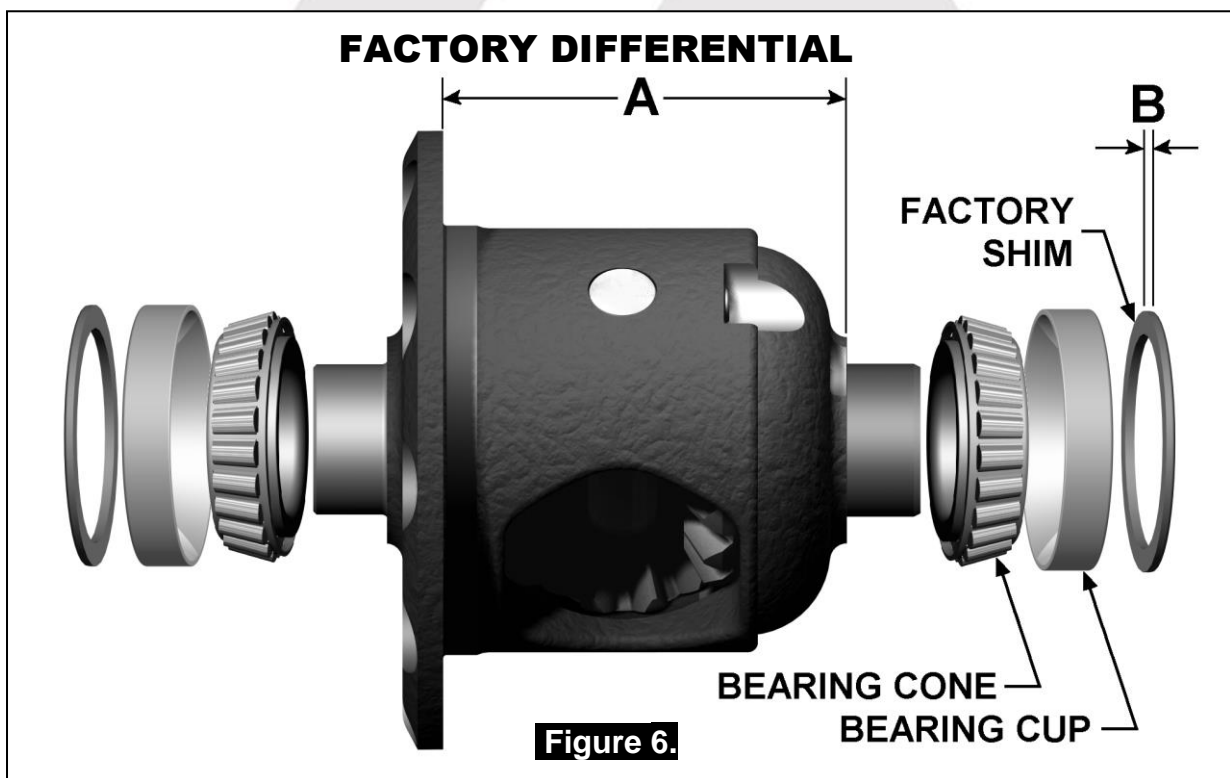

3 Installing the Air Locker

- Using a caliper or similarly accurate measurement method (i.e., able to take accurate measurements within 0.04mm [0.0015"]), measure the distance from the shoulder of the bearing journal to the ring gear mounting face (shown as 'A' in Figure 6.) and record this measurement as 'A'.
- Measure the thickness of the factory shim removed from the end of the differential carrier (shown as 'B' in Figure 6.) and record this measurement as 'B'.

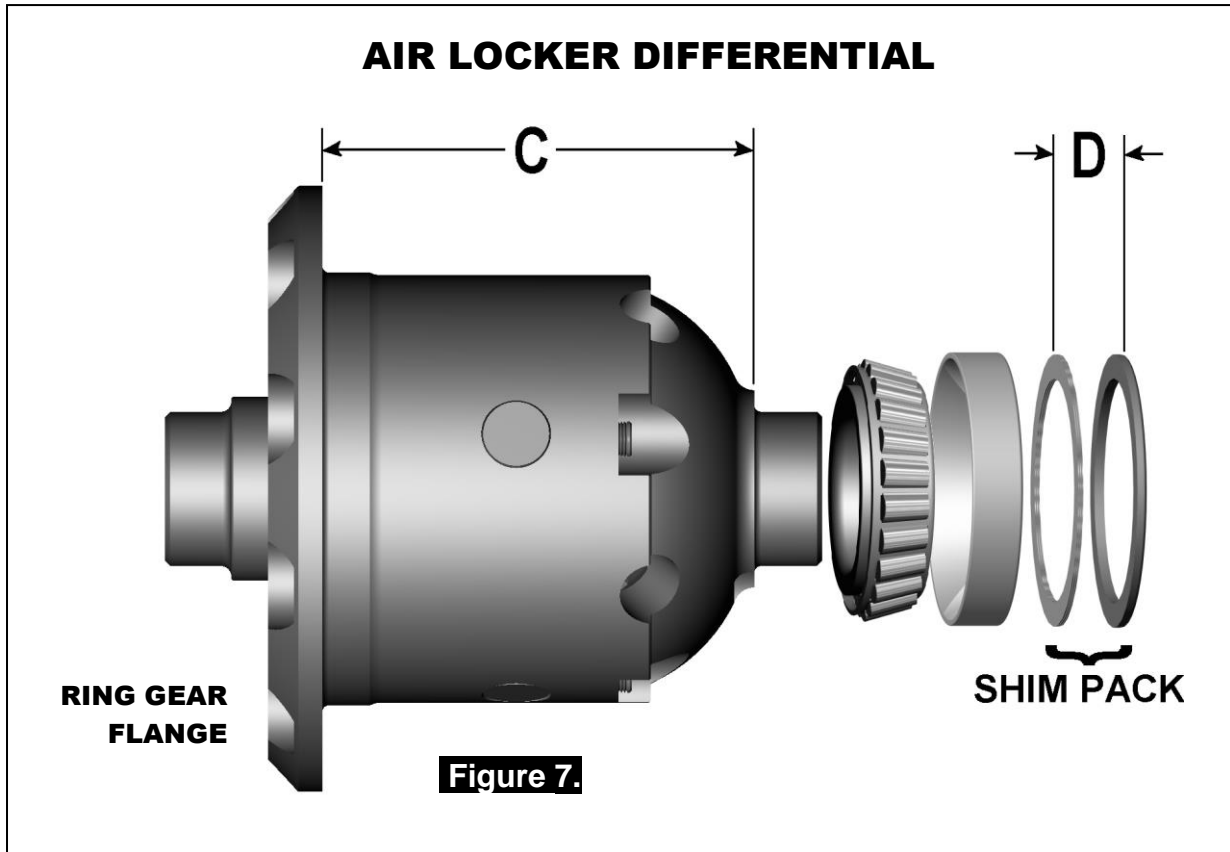

- Measure the distance from the *Air Locker* bearing shoulder to the ring gear mounting face (shown as 'C' in Figure 7.) and record this measurement as 'C'.

3 Installing the Air Locker

3.2 **A B** Calculation & Selection of Backlash Shims

Ideally, the measurement you recorded as 'C' from the *Air Locker* differential will closely match 'A' on the existing differential (within 0.1mm [0.004"]) and then the factory shim can be reused, however, quite often these measurements will vary slightly between one factory differential and the next.

If this is the case you must create a new shim pack thickness by using the measurements you recorded earlier to find a desired measurement for 'D' in Figure 7.

Use the following calculation:

$$A + B - C = D \text{ (Replacement Shim Pack)}$$

HINT : If your calculations are correct then the following calculation will also be true:

$$A + B - C - D = \text{ZERO}$$

Create a shim pack to match the thickness calculated as 'D'.

To achieve the desired shim thickness you can:

- Machine down the factory shim thickness.
- Add shims between the factory shim and the bearing cup.

HINT : A selection of shims of this size have been supplied with your *Air Locker* kit.

- Purchase new factory shims at the desired thickness.
- Use a universal shim kit available from most drive train specialists.
- Add small amounts of shim between the bearing cone and the bearing seat.

NOTE : NEVER machine the *Air Locker*.

3 Installing the Air Locker

3.3 A B Mounting the Ring Gear

- Apply a thin film of high pressure grease to the ring gear shoulder of the *Air Locker* to prevent seizing.
- Thoroughly clean any thread locking compound or other foreign matter from the holes of the ring gear, the threads of the ring gear bolts, and the mating surfaces between the ring gear and the *Air Locker* flange.

HINT : **Stoning the ring gear mounting face before installation will remove any high spots around the threads.**

- Heat the ring gear to between 80 and 100°C [175 - 212°F] in hot water or in an oven to slightly expand the gear and facilitate assembly.

NOTE : **NEVER HEAT GEARS WITH A FLAME! This could damage the hardened surface of the gear and result in premature wear or failure.**

- Dry the gear and bolt holes with compressed air (if wet).
- Install the ring gear onto the *Air Locker* by aligning the bolt holes and then gently tapping it around in a circle with a soft mallet. Avoid using the bolts to pull down the ring gear as this puts excess strain on the bolts and the differential flange.
- Apply a thread locking compound to the thread of each ring gear bolt before inserting it. Do not apply threading compound directly into the threaded hole as this could prevent the bolt from reaching its full depth.
- Tighten the ring gear bolts in a star pattern with a torque wrench according to your vehicle manufacturer's specified torque.

3 Installing the Air Locker

3.4 A B Installing the Carrier Bearings

- Apply a thin film of high pressure grease to both bearing journals of the *Air Locker*.
- Using a bearing press or arbor press, press one of the original tapered roller bearing cones onto the bearing journal opposite to the ring gear flange of the differential carrier (As shown in Figure 8.) until the bearing seats firmly against the bearing journal shoulder.



- Invert the *Air Locker* and press the bearing cone which was supplied with the *Air Locker* kit onto the bearing journal on the ring gear flange side of the differential (the seal housing side) until the bearing seats firmly against the bearing journal shoulder.

NOTE : Never re-use any bearings which are damaged or worn. Do not add any shims between the seal housing bearing and the bearing seat.

3 Installing the Air Locker

3.5 A B Preload Shim Measurement

In order to preload the tapered roller bearings in your *Air Locker*, measurements need to be taken so that a value can be calculated for the total shim thickness 'E' in Figure 9.

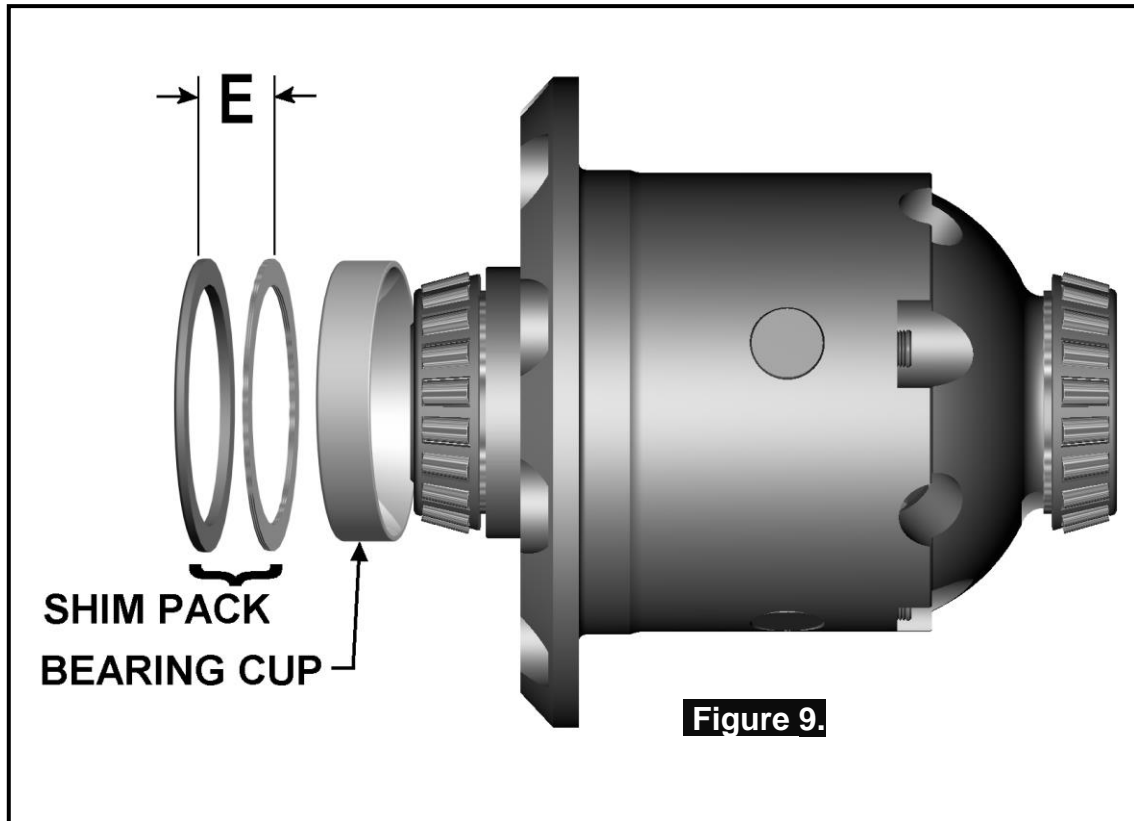

Figure 9.

3.5.1 A Front Access Housing Preload

- Hold the bearing cups in place over their matching bearing cones.
- Insert and hold the *Air Locker* into the differential housing.
- Insert the shim pack determined earlier as 'D' between the bearing cup (right hand side as shown in Fig.7.) and the differential housing.
- Push (or lightly pry) the *Air Locker* hard across to the right-hand side, and measure the gap (also called the 'end float') between the bearing cup and the housing with a feeler gauge.
- Record this measurement.

3 Installing the Air Locker

3.5.2 B Clamshell Housing Preload

- Assemble the shim pack determined earlier as 'D' (Fig.7.) into the bearing bore of the deep half of the clamshell.
- Using a bearing press or arbor press, press one of the original bearing cups into the bottom of the same bearing bore (i.e., until it stops against the shim pack).

HINT : You should not be able to rotate the shim pack underneath the bearing cup if it has been pressed in far enough.

- With the deep half of the clamshell sitting firmly on a horizontal surface, set the *Air Locker* into the bearing cup inside the clamshell.
- Assemble the bearing cup supplied with the *Air Locker* kit onto the bearing cone now positioned at the top of the *Air Locker*.
- Put any remaining shims from the *Air Locker* shim kit (supplied) together and measure the total thickness.
- Set the shim pack on top of the bearing cup (i.e., the position of shim pack 'E' in Fig.10.).
- Carefully assemble the shallow half of the clamshell over the top of the *Air Locker*.
- Measure the preload gap that exists between the two halves of the clamshell housing with a feeler gauge. (Refer to Fig.10.)

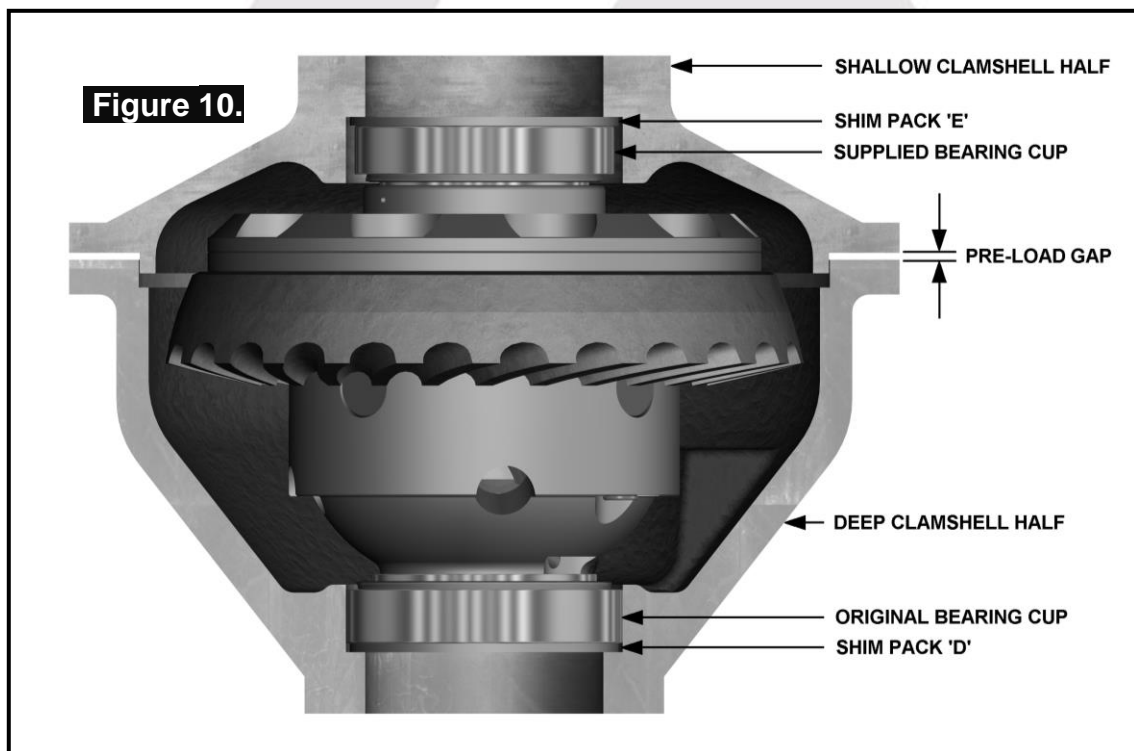

3 Installing the Air Locker

NOTE : The preload gap should be the same when measured all the way around the housing. If this is not true, then reposition the shallow clamshell half and re-measure.

- Subtract the amount measured at the preload gap from the thickness of the shim pack placed on top of the bearing cup.
- Record the result as this is your true 'end float' amount.

3.6 **A B** Calculation & Selection of Preload Shims

- Consult your vehicle manufacturer's service manual to determine the carrier bearing preload amount specified for your vehicle.

NOTE : If your service manual specifies preload in terms of a torque value measured off the drive pinion flange, then assume a preload amount of 0.25mm [0.01"] for the following calculations. Once you have assembled the housing to check the final backlash (Refer to Section 3.12 *Checking the Backlash*) you should verify that your preload is correct using a torque wrench and your service manual's table of values.

- Add the specified preload amount to the end float measurement determined with the feeler gauge to determine a shim amount for 'E' (Refer to Figure 9.).

PRELOAD + END FLOAT = SHIM PACK

- Create a shim pack 'E' to closely match the measured amount.

NOTE : When creating the shim pack 'E', use at least 0.75mm [0.030"] of the Air Locker shim pack between the factory shim and the bearing cup in order to prevent the cage of the bearing from contacting the factory shim.

To achieve this desired shim thickness you can:

- Machine down the factory shim thickness.
- Add shims between the factory shim and the bearing cup.
- Purchase new factory shims at the desired thickness.
- Use a universal shim kit available from most drive train specialists.

NOTE : Do not add shims between the bearing cone and the bearing seat and **NEVER** machine the *Air Locker*.

3 Installing the Air Locker

3.7 A B Drilling & Tapping the Bulkhead Port

A port must be drilled and tapped through the differential housing to allow the seal housing tube through the housing to connect with the air line from the air compressor.

- Remove the *Air Locker* from the housing.

3.7.1 A Front Access Housing Port Location

- Mark a spot on the top of the outside shell of the differential housing in the position shown in Figure 11. The location should be about 45mm [1.75"] from the gasket face of the cover flange and very close to the teeth of the ring gear inside.

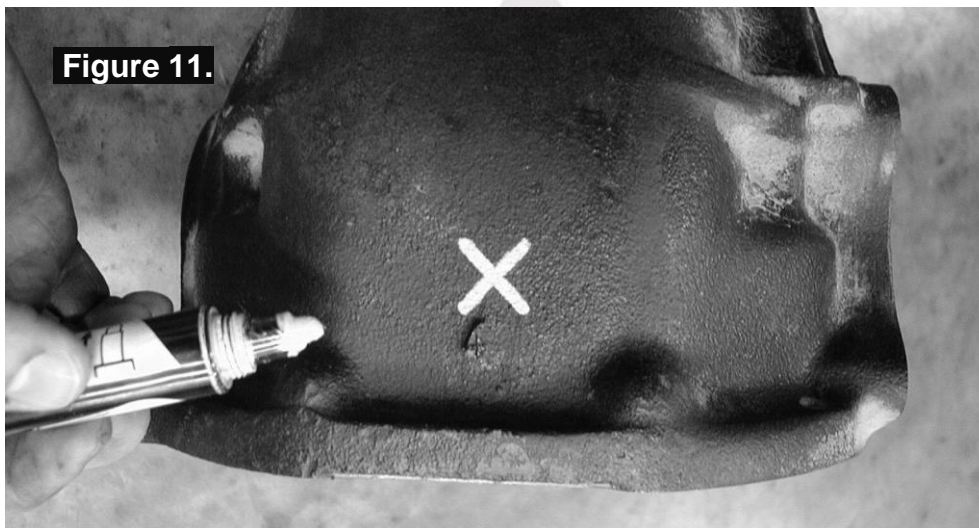

- Cover the drive pinion and bearing seat areas with rags to protect them from metal filings.
- Drill through the housing square to the outside surface using a 11.2mm [7/16"] drill.
- Tap the hole from the outside using a 1/4" NPT pipe tap.
- Remove any sharp edges from the hole that may chip-off and fall into the housing.
- Carefully remove the rags and inspect with a service light inside the housing to insure no metal filings are left behind.

3.7.2 B Clamshell Housing Port Location

- Mark a spot on the inside of the shallow half of the clamshell (i.e., as close to the center of the housing as possible) that is in the same location as the bulkhead port position shown in the photograph in Figure 12.

3 Installing the Air Locker

HINT : Use the location of the oil vent hole to gauge where the position should be.

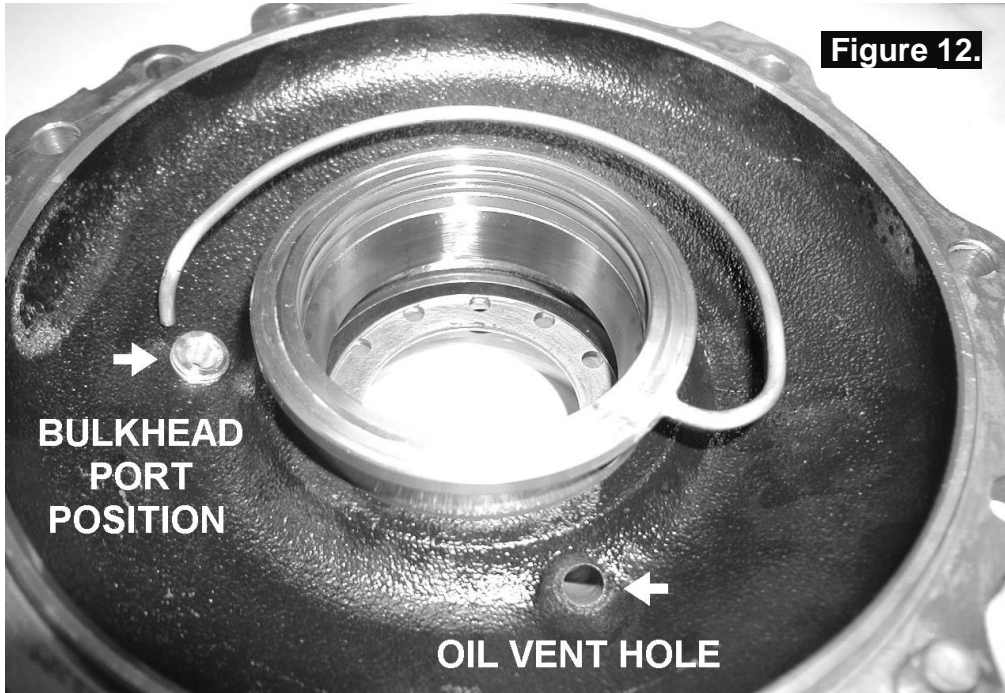

NOTE : The photograph shows the bulkhead body already installed and the seal housing sitting in position where it will be pressed in later on.

- Cover the bearing seat area with a rag to protect it from metal filings.
- Drill through the housing square to the outside surface (i.e., with the drill body angled slightly towards the center from the inside) using an 11.2mm [7/16"] drill.

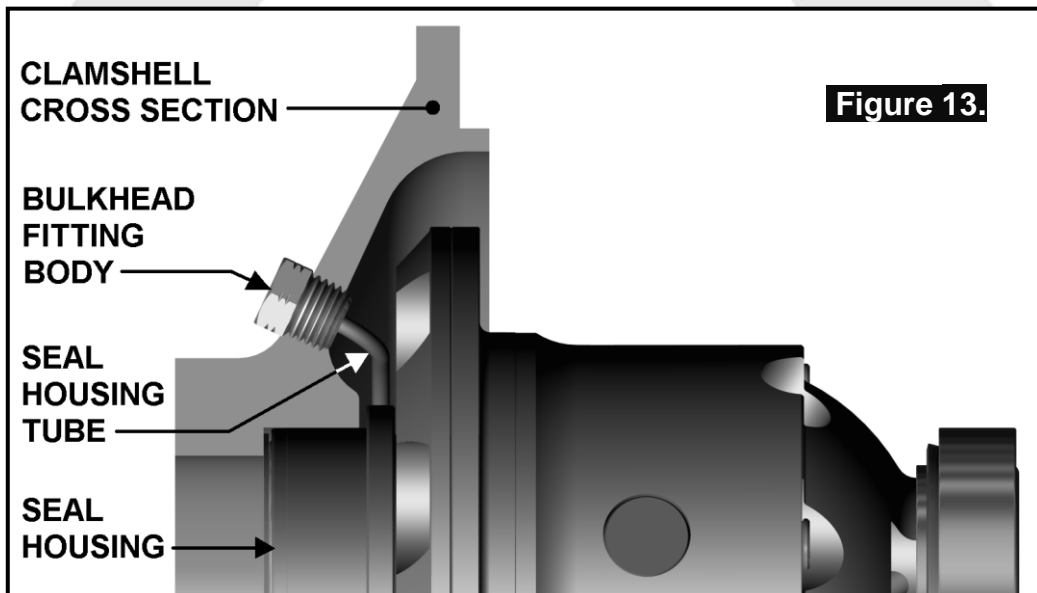

3 Installing the Air Locker

NOTE : The drawing in Figure 13. shows a cross section of the bulkhead body installed into the clamshell. This shows how critical it is to position the bulkhead port on an angle of approximately 25° in the deepest part of the cavity in the clamshell to allow room for the seal housing tube.

- Tap the hole from the outside using a ¼” NPT pipe tap.
- Remove any sharp edges from the hole that may chip-off and fall into the housing.
- Carefully remove the rag and inspect with a service light inside the housing to insure no metal filings are left behind.

3.8 **A B** Installing the Bulkhead Fitting

- To obtain an oil tight seal, apply a thread sealant to the threads of the bulkhead body, screw it into the bulkhead port (from the outside), and tighten.
- Wipe the area clean of any excess thread sealant (inside and outside of the housing).

3.9 **A B** Installing the Differential Center

- Apply a thin film of high pressure grease to the outside of the tapered roller bearing cup supplied with the *Air Locker*.
- Using a bearing press or arbor press, press the bearing cup into the seal housing (narrow edge first) until it stops at the end of the bore.

NOTE : Do not install the bearing cup upside down. Refer to Figure 14. for the correct installation direction. Be careful not to bend the seal housing tube or damage the O-ring grooves.

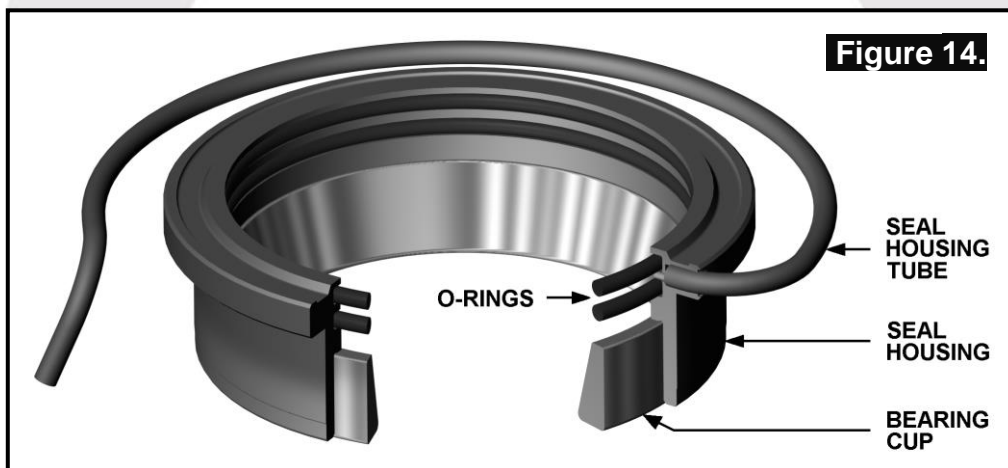

3 Installing the Air Locker

- Make sure the seal housing tube and the grooves of the seal housing are clean and free from any contaminants (e.g., water, dirt, metal filings, etc.).
- Inspect the seal housing O-rings (supplied) for dirt, damage or other conditions which might cause leaks.
- Generously lubricate the O-rings with oil prior to assembly, then insert them into the grooves of the seal housing.

NOTE : When assembling the O-rings, be careful not to leave them twisted when seated in the grooves as this could cause excessive wear and leakage.

3.9.1 A Front Access Housing Installation

- Without using sharp, jagged tools such as pliers (usually your hands are the best tool for this job), gently straighten the large curve of the seal housing tube leaving only the sharp bends at both ends of the tube.
- Install the seal housing onto the *Air Locker* by carefully sliding it over the bearing journal by hand with a gentle twisting motion. This will allow the O-rings to engage gently.
- Rotate the seal housing a few turns to make sure it rotates freely and smoothly.
- While holding the bearing cup onto the carrier bearing opposite to the seal housing, insert and hold the *Air Locker* into the differential housing with the seal housing solder joint rotated to the top of the differential housing (i.e., in line with the bulkhead port).
- Bend the seal housing tube around the outside of the ring gear until the end of the tube can be inserted through the hole in the bulkhead fitting.
- Assemble the shim packs 'D' and 'E' into their correct positions between the bearing cups and the bearing bore of the housing.

NOTE : If the shim pack is too difficult to install then the shims may need to be tapped in. Be careful not to damage the shim packs while installing them.

- Install the bearing caps oriented as they were marked before they were removed, and tighten the bearing cap bolts. It is not necessary to torque them down at this time.
- Check that some backlash can be felt between the ring and pinion gears. No backlash would be an early indication of incorrect shim thickness.

3 Installing the Air Locker

3.9.2 B Clamshell Housing Installation

- Assemble the shim pack 'E' (Fig.9.) into the bearing bore of the shallow half of the clamshell.
- Position the seal housing in the same bearing bore so that the end of the seal housing tube is in line with the bulkhead port position (Refer to Figure 15.).

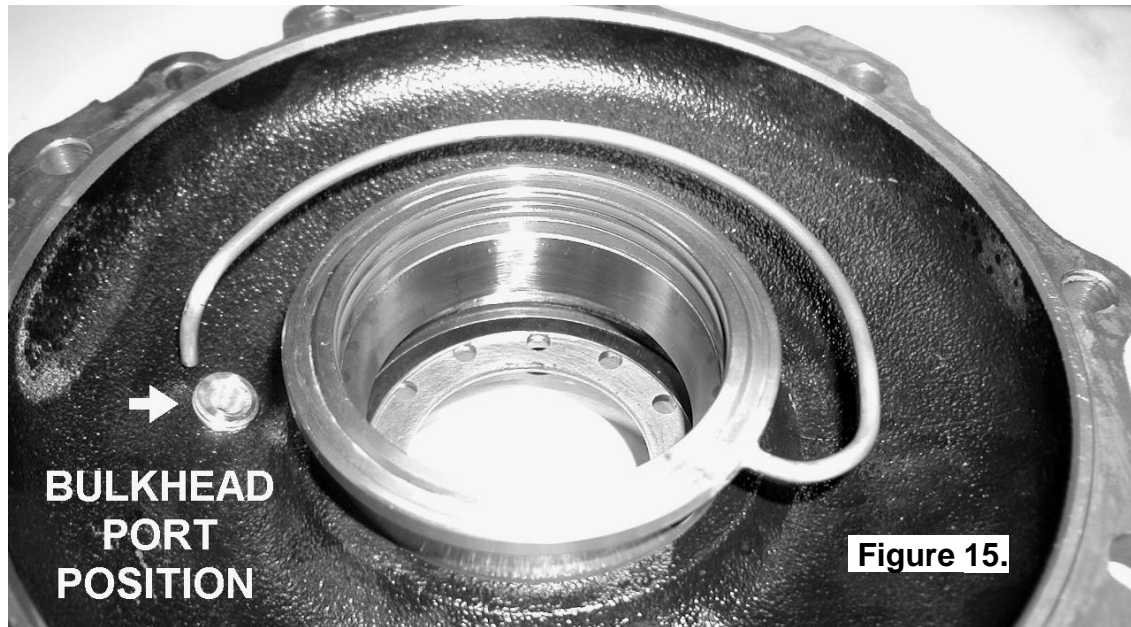

- Using a bearing press or arbor press, press the seal housing assembly into the bottom of the bearing bore (i.e., until it stops against the shim pack).

NOTE : Do not use excessive force when pressing as this may damage the seal housing assembly.

HINT : You should not be able to rotate the shim pack underneath the bearing cup if it has been pressed in far enough.

3 Installing the Air Locker

3.10 **A B** Setting Up the Bulkhead Fitting

- Insert the end of the seal housing tube into the bulkhead fitting and hold it to its full depth.
- From the outside of the housing, assemble one of the small O-rings over the top of the short length of seal housing tube protruding through the bulkhead fitting.
- Install the brass spacer.
- Install the second small O-ring after the spacer.
- While holding the seal housing tube into the bulkhead fitting, insert the chamfered end of the center compression nut over the extended tube as shown in the assembly diagram (Fig. 16.), and screw it into the bulkhead body, and tighten using Pozidriv #3 screwdriver.

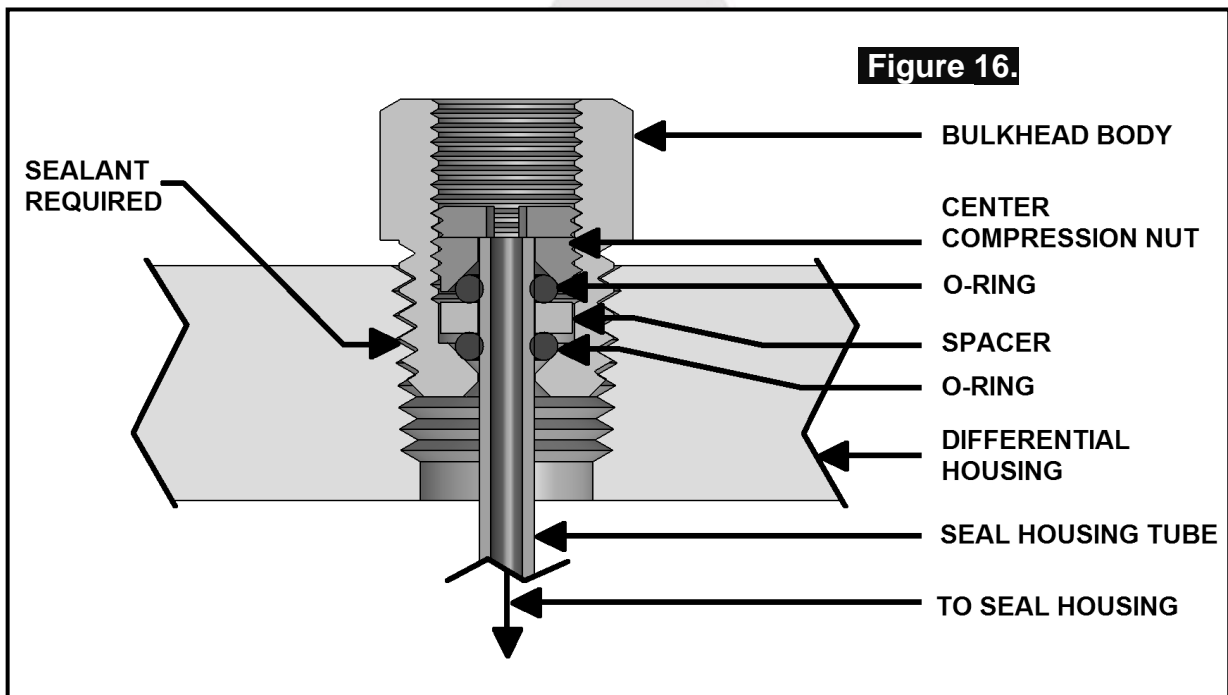

NOTE : Make sure the seal housing tube is all of the way into the center compression nut while you are tightening it.

NOTE : Firmly tighten the center compression nut so that a good seal is formed around the tube.

3 Installing the Air Locker

3.11 A B Final Assembly

The seal housing tube needs to be carefully bent so that it will stay clear of any moving parts of the differential and not rub against any sharp stationary edges on the bearing cap or the differential housing.

3.11.1 A Front Access Housing Tube Profile

- Without using sharp, jagged tools such as pliers (usually your hands are the best tool for this job), gently bend the seal housing tube so that it closely follows the profile of the ring gear. (Refer to Fig.17.)



Figure 17.

NOTE : Any contact due to vibration or shock could wear the tube over time and eventually cause a leak. Keep the tube away from any sharp edges of the bearing cap or any other part of the differential housing.

- Position the aluminum access cover in its installed position to check that no part of the tube comes in contact with it.
- Check the gap between the *Air Locker* and any close points on the seal housing tube with a feeler gauge to insure that adequate clearance exists. (Refer to Fig.18.)

NOTE : Less than 8mm [5/16"] should be considered too little clearance.

3 Installing the Air Locker

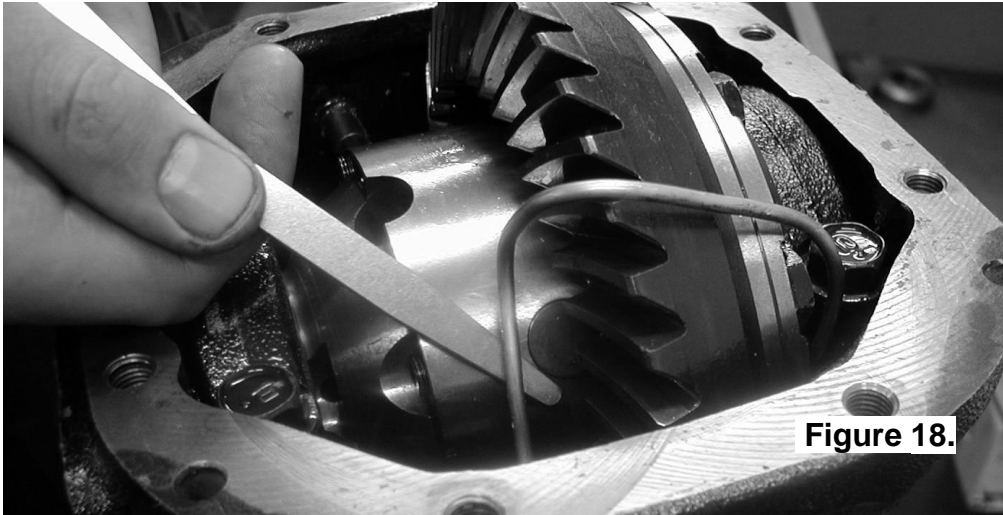

3.11.2 **B** Clamshell Housing Tube Profile

- Press the seal housing tube flat to the back of the housing as shown in Figure 19.



- Insert the *Air Locker* into the seal housing by gently lowering it into the bearing cup with a gentle twisting motion. This will allow the O-rings to engage gently.
- Rotate the *Air Locker* a few turns to make sure it rotates freely and smoothly.
- Carefully assemble the deep half of the clamshell over the top of the *Air Locker*.
- Bolt the clamshell assembly closed.
- Check that some backlash can be felt between the ring and pinion gears. No backlash would be an early indication of incorrect shim thickness.

3 Installing the Air Locker

3.12 A B Checking the Backlash

- Refer to your vehicle manufacturer's service manual for the specified maximum and minimum amounts of backlash. If the backlash measured here is not within the specifications then the differential will have to be re-shimmed.

3.12.1 A Backlash for Front Access Housing

- Tighten all bearing cap bolts with a torque wrench to the torque specified in your vehicle manufacturer's service manual.
- Set a plunge type dial indicator on one of the ring gear teeth as in Figure 20.

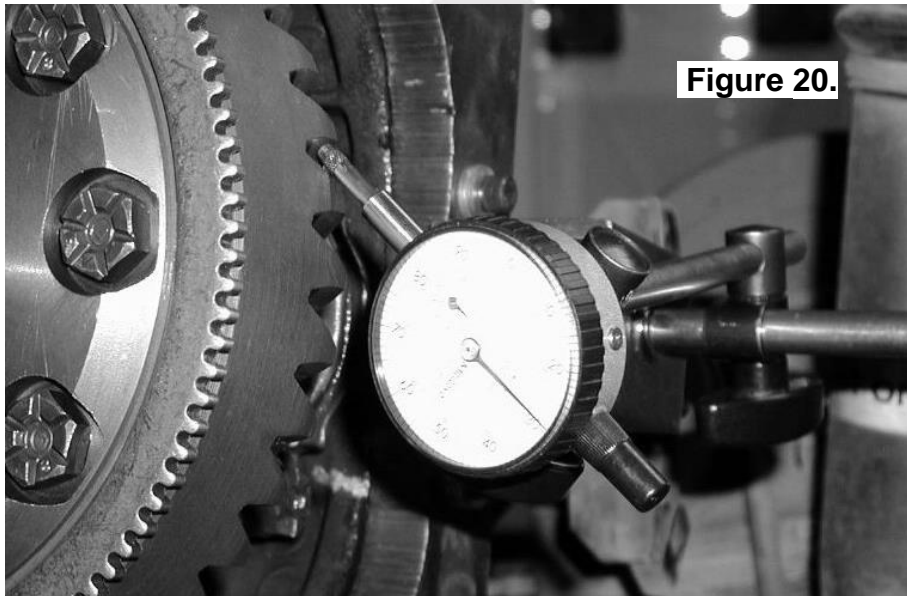

Figure 20.

- While supporting the pinion gear by holding the drive shaft, rotate the differential in both directions while observing the maximum variation in depth from the indicator (i.e., the highest value minus the lowest value). This value is referred to as the ring and pinion backlash.
- Rotate the differential center 90° and measure again for accuracy.
- Record the average of all measurements.

3.12.2 A Re-Shimming the Backlash

NOTE : This step is only necessary when adjusting for incorrect backlash.

- Remove the bearing caps.
- Remove the shim packs from both ends of differential.

3 Installing the Air Locker

- To decrease the amount of backlash, reduce the shim thickness 'D' (Fig.7.) and increase the shim thickness 'E' (Fig.9.) by the same amount. Reverse this step to increase the backlash.
- Remount the differential as before.
- Check backlash again as before.

3.12.3 **B** Backlash for Clamshell Housing

- Set a long series lever type dial indicator on one of the ring gear teeth. Access to the ring gear teeth is gained through the oil filler hole. (Refer to Figure 21.)



- Insert a large flat screwdriver or pry-bar through one of the axle stub holes so that it wedges between the cross shaft and the carrier body so that the differential center can be rotated by the cross shaft (not by the spline of one of the differential gears).
- While supporting the pinion gear by holding the drive shaft flange, rotate the differential in both directions (with the screwdriver or pry-bar) while observing the maximum variation in depth from the indicator (i.e., the highest value minus the lowest value). This value is referred to as the ring and pinion backlash.
- Rotate the differential center 90° and measure again for accuracy.
- Record the average of all measurements.

3 Installing the Air Locker

3.12.4 **B** Re-Shimming the Backlash

NOTE : This step is only necessary when adjusting for incorrect backlash.

- Remove the bolts from the clamshell housing.
- With the shallow half of the clamshell sitting firmly on a horizontal surface, lift off the deep half of the clamshell.
- Gently lift the *Air Locker* straight upward out of the seal housing in the shallow half of the clamshell.
- Remove the center compression nut from the bulkhead fitting. (Fig.16.)
- Pull the seal housing tube free of the bulkhead fitting.
- Using an arbor press or bearing press, press out the seal housing assembly and the bearing cup from the deep half of the clamshell.
- To decrease the amount of backlash, reduce the shim thickness 'D' (Fig.7.) and increase the shim thickness 'E' (Fig.9.) by the same amount. Reverse this step to increase the backlash.
- Reinstall the *Air Locker* into the differential assembly.
- Check backlash again as before.

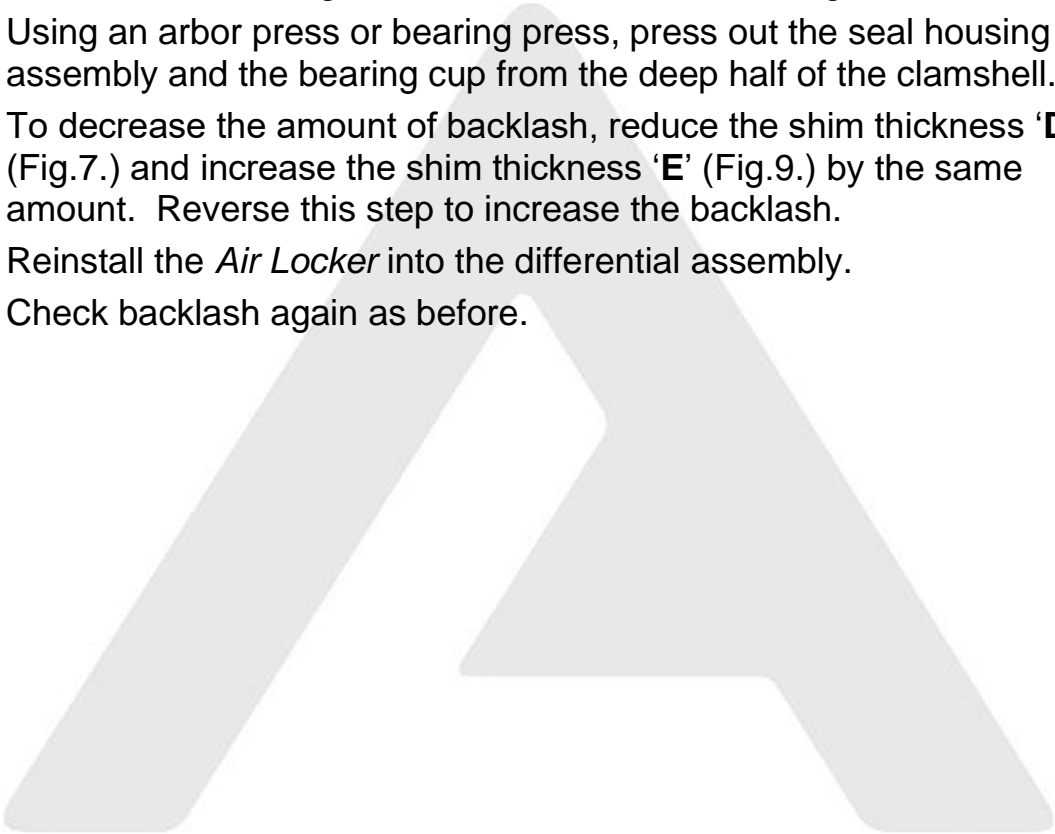

3 Installing the Air Locker

3.13 A B Bench Testing the Air Locker

- To bench test the *Air Locker*, when 620kPa [90 PSI] shop air is applied to the seal housing tube, the *Air Locker* should engage.
- Check all fittings and the seal housing for air leaks.
- Rotate the differential carrier by turning the pinion flange whilst applying air pressure.

NOTE : An accurate way to test for air leaks is to fit a shut-off valve to an air pressure gauge. (ARB part # ALTG01 shown in Fig.22.) Once 620 KPA [90 PSI] is reached close the valve, disconnect the air hose, and watch to see if there is any drop in pressure. If so, this will indicate an air leak.



Figure 22.

- If a leak is found to be present, spray a soap and water mixture onto the bulkhead air fitting. Bubbles should appear at any leak points.

NOTE : Do not spray this soapy mixture inside the differential.

- Check that leaky fittings have been adequately tightened.
- Disassemble, clean threads, and reapply thread sealant if leaking persists.
- If a leak is found at the seal housing, remove the *Air Locker* and carefully remove the seal housing assembly and examine the O-rings. Be very careful with the O-rings and check for defects, damage, wear, or presence of foreign material in the O-ring grooves. Replace if necessary.

3 Installing the Air Locker

3.14 **A B** Reinstalling the Differential Assembly

- Reassemble the differential assembly according to your vehicle manufacturer's service manual using gasket sealant where necessary.

NOTE : Be careful not to damage the sintered bushings in the ends of the *Air Locker* when installing axle stubs. The fit should be snug, and light tapping may be required to fully insert the stubs fully into the splines. In some cases a small chamfer may need to be ground onto the axle stubs as a lead-in for insertion into the bushings.

- Install the differential assembly into the vehicle.
- Insert both CV axles fully into the housing and gently tap them inward until the retaining clips have seated.

NOTE : Be careful not to damage oil seals with the axles.

- Reassemble brakes and wheels according to your vehicle's service manual.
- Reconnect the drive shaft flange.

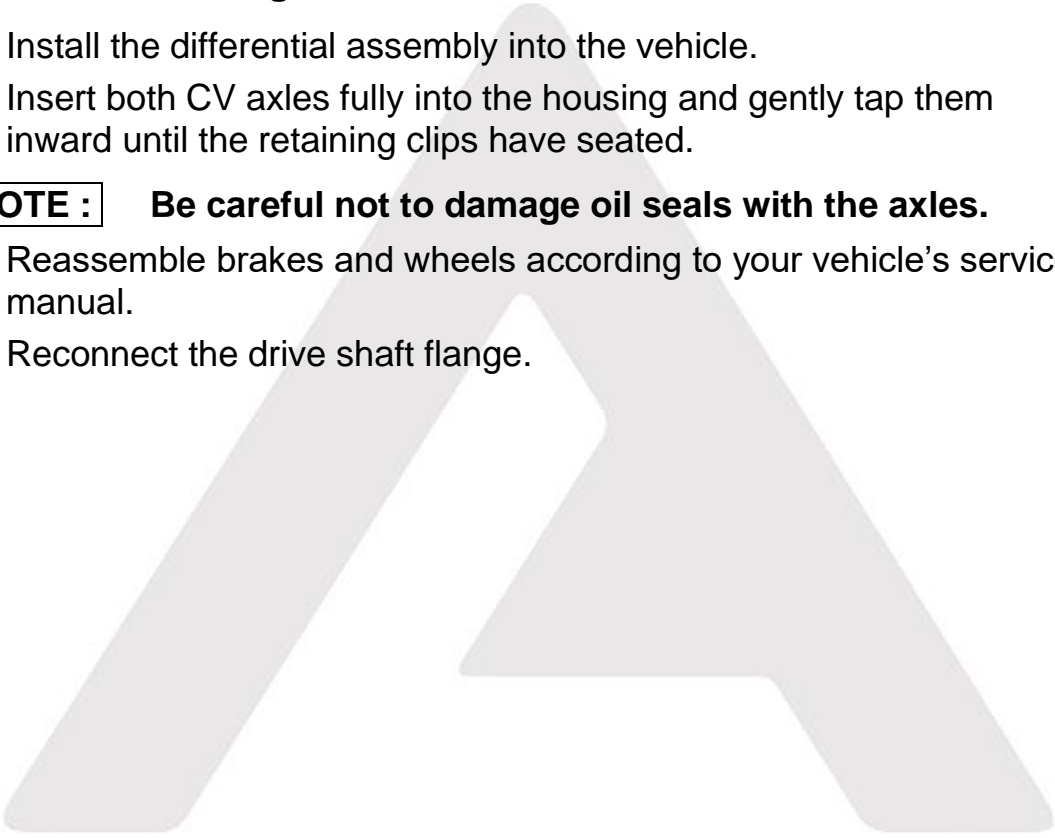

4 Installing the Air System

4.1 Mounting the Solenoid

4.1.1 Connection to an ARB Air Compressor (Fig.23.)

- Remove one of the 1/8" BSP plugs from its port in the compressor tank.
- Apply Teflon paste to the 1/8" BSP nipple on the solenoid and insert it into the port and tighten. The solenoid should be rotated into a position which does not obstruct any other ports on the compressor tank.

NOTE : The coil and stem of the solenoid can be removed to make installation easier.

NOTE : The solenoid is marked with two #1 ports. If space is tight, a second solenoid can be "daisy-chained" off the first one by removing the plug from the redundant #1 port and screwing the nipple from the second solenoid into it (Fig. 23.).

NOTE : The solenoid exhausts compressed air through the center of the black retaining cap when the *Air Locker* is disengaged. Make sure this orifice cannot be obstructed.

- Assemble the 6mm push-in fitting into the solenoid outlet port (stamped "2") and hand tighten.

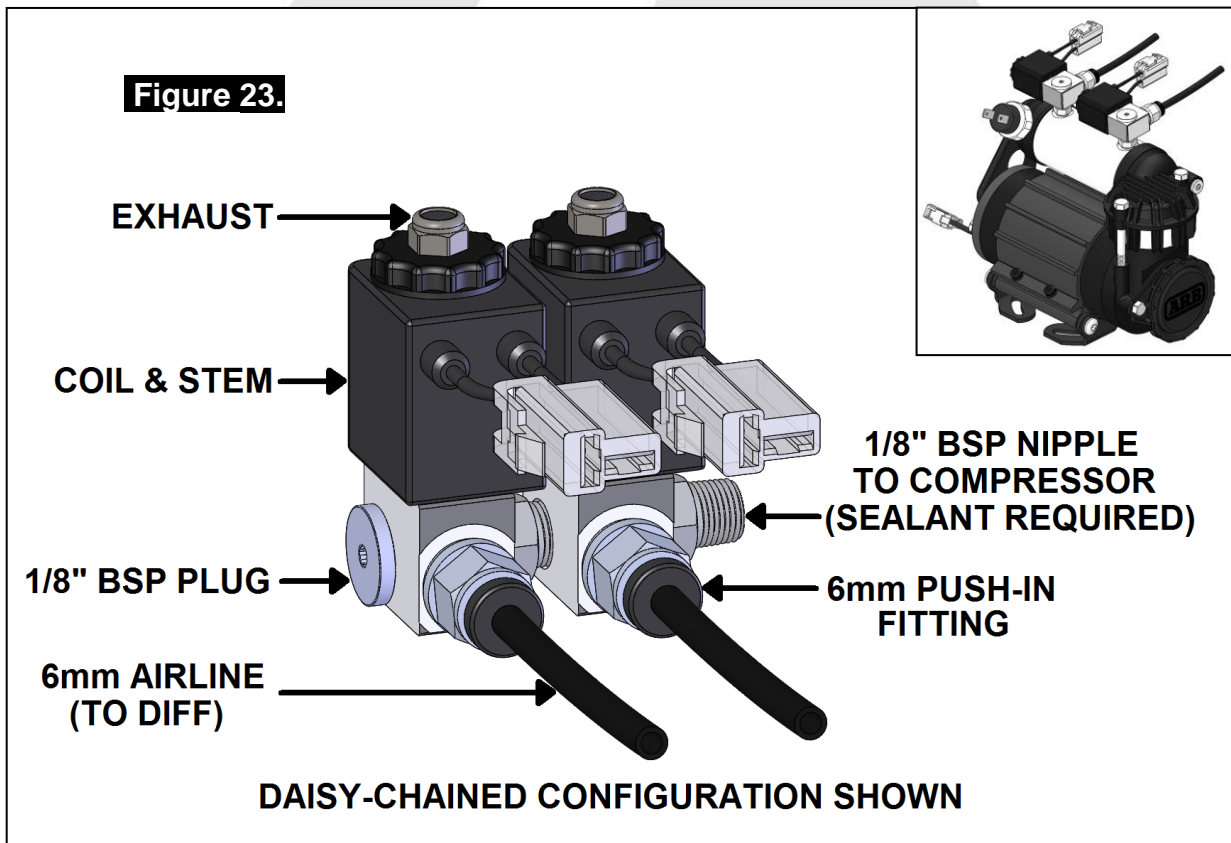

4 Installing the Air System

4.1.2 Connection to an Alternate Air Source

For ease of installation, quality of air supply, and a high level of dependability from your *Air Locker(s)*, ARB strongly recommends use of a genuine *ARB Air Compressor*, however, the *Air Locker* air system can be operated on any alternate air source that meets each of the following guidelines:

- Must supply a minimum of 85PSI [586kPa].
- The air source should have a tank capacity which enables it to actuate the *Air Locker(s)* in one charge so that no hesitation is experienced when locking one or two differentials.

HINT : A good way to insure that you have the necessary capacity is to make sure you can engage, disengage, and then reengage your *Air Locker(s)* without the air source having to regenerate (e.g., without the compressor turning on to refill the tank).

- Must supply clean air, free of rust, dirt, water, or other foreign matter.
- Must match the 1/8" BSP porting of the *Air Locker* solenoid.
- Mount solenoid within close proximity of the air supply and secure it from the effects of vibration and shock.
- Connect the air supply to the 1/8" BSP inlet port of the solenoid (stamped "1" on the solenoid body) using thread sealant.

IMPORTANT :

ARB cannot warranty your *Air Locker(s)* against damage caused as a result of using an alternate air supply. If you have any doubts as to the suitability of your air system to use in an *Air Locker* system, consult your ARB distributor.

4 Installing the Air System

4.2 Running and Securing the Air Line

The path taken by the air line from your air source (i.e., compressor) to your *Air Locker* is unique to your vehicle and the position of your air source. Plan ahead carefully when running the air line and always follow these guidelines:

- Account for axle travel when running the line from the axle to a fixed point on the vehicle. Leave enough slack in the air line to allow for maximum suspension travel in both directions.
- Avoid leaving large lengths of air line hanging underneath the vehicle where they may get tangled on rocks, sticks, etc.

HINT : **Cable tying the air line to one of your flexible brake lines will account for axle travel and should help keep your line from getting snagged.**

- Run the air line all the way from the compressor to the differential before trimming either end of the line to length. This will save complications which may arise if the air line has to be removed.
- Make sure the line does not contact sharp edges or abrasive surfaces that may damage the air line over time.
- Do not run the air line around tight bends which may kink the air line and restrict or block the air flow.
- Keep the air line well away from your vehicle's exhaust components. Air lines will melt if subjected to extreme heat.
- Do not run more air line than necessary. Excess line volume created when coiling the left over hose, using unusually large diameter hose, etc., will increase drain on the compressor tank resulting in the compressor running more often than needed.
- Support the air line by tying it back with cable ties wherever possible.
- At the solenoid end of the air line, trim the line to length with a sharp knife.
- To attach the air line to the push-in fitting of the solenoid; insert the line firmly into the fitting, pull outward on the flange of the fitting while holding the line as far into the fitting as possible, and then gently pull outward on the air line to clamp the line in place.

NOTE : **To remove the air line from the push-in fitting; pull outward on the flange of the fitting, push the air line as far into the fitting as possible and hold, push inward on the flange, and then pull the air line free of the fitting.**

4 Installing the Air System

4.3 Connection to the Bulkhead Fitting

- Trim the air line to length using a sharp knife.
- Assemble an aluminium washer onto the banjo bolt and insert through the banjo fitting. Assemble second aluminium washer and tighten into bulkhead fitting using a 14mm [9/16"] spanner. (Fig.24.)
- Apply thread sealant to the tapered thread of the compression fitting body and screw into the banjo fitting. Tighten using a 12mm spanner.
- Insert the outer compression nut and ferrule over the air line. Ferrule should be orientated as per Fig.24.

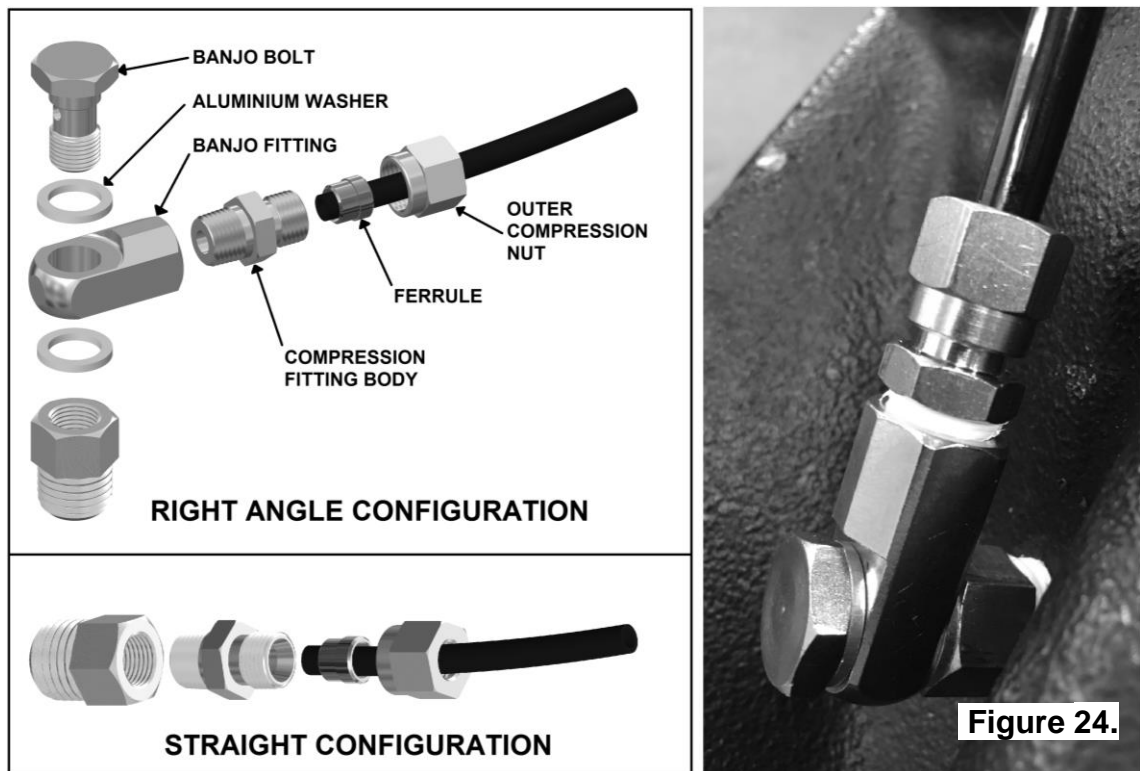

- Push the airline into the compression fitting body and screw the outer nut down onto it. Using a 12mm spanner, tighten the outer nut onto the compression fitting body.

NOTE : Some force is required to crush the ferrule, however the outer compression nut will tighten against a stop. Over tightening will not create a better seal.

- Secure any loose sections of tube with a cable tie.

NOTE : When right angle routing of the tube is not required, screw the compression fitting body straight into the bulkhead fitting body (Fig.24.).

5 Mounting & Connecting the Electrical System

5.1 Mounting the Actuator Switch(es)

Air Locker actuator switch(es) can be easily panel mounted inside the vehicle in a 21mm x 36.5mm [0.83" x 1.44"] rectangular cutout.

NOTE : Only attach the cover plate to the face of the switch once the switch has been mounted and wired correctly as the cover plates are designed to be difficult to remove.

For reasons of safety and for ease of operation, the *Air Locker* actuator switch(es) should be mounted in a location picked to best suit the operator. Make sure you have taken the following points into consideration:

- Switch(es) **MUST** be mounted and should never be allowed to simply dangle from the wiring loom during vehicle use.
- Switch(es) should be within easy reach of the driver. Ideally, any *Air Locker* switch should be able to be operated without physical effort or distraction to the driver. Switch(es) should be mounted within the line of sight of the driver so that switch position ('ON' or 'OFF') can be visually determined by the rocker position and the illumination state.
- The position of the switch(es) should best eliminate any possibility of accidental operation by the driver or one of the passengers.
- Switch cutout position(s) must be located in an area with a minimum of 50mm [2"] of clearance behind the face of the cutout
- Switch(es) should not be mounted where they will be exposed to water (e.g., in the lower section of an inner door panel).
- ARB recommends that you apply the *Air Locker* warning sticker (ARB part # 210101) within close visual proximity of the switch location.

NOTE : If no adequate position can be found on existing dashboard panels, a surface mounted bracket (Fig.25.) may be purchased from your *ARB Air Locker* distributor to suit 1, 2, or 3 switches.

Figure 25.



5 Mounting & Connecting the Electrical System

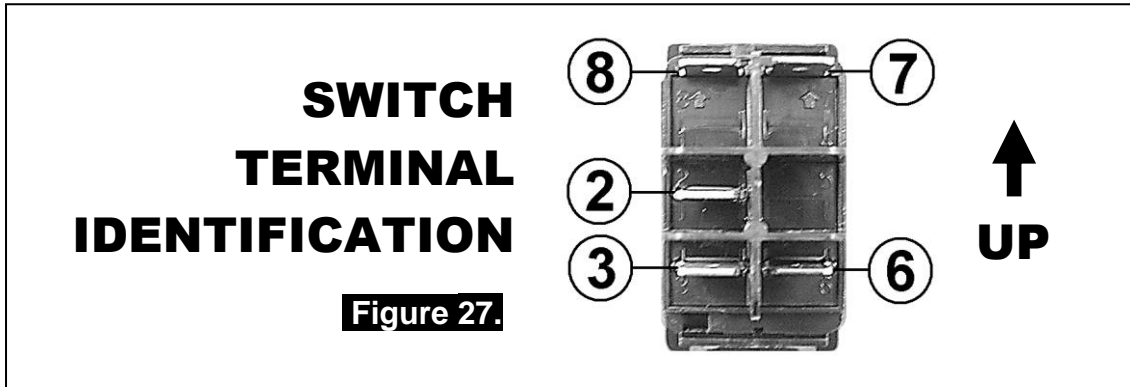

5.2.2 Connection to an Alternate Air Source

When connecting the actuation switch to an alternate air source, the switch(es) should be wired according to Figures 28. and 29., depending on whether one or two *Air Lockers* will be installed in the vehicle.

5.2.2.1 Single Air Locker System

- If only one *Air Locker* is to be installed in the system, the switch and solenoid should be wired according to Figure 28. regardless of whether the *Air Locker* has been installed in the front or rear axle of the vehicle.
- Attach the appropriate switch cover (i.e., 'FRONT' or 'REAR') to the switch.

NOTE : Refer to Figure 27. for the correct switch terminal identification and switch orientation.

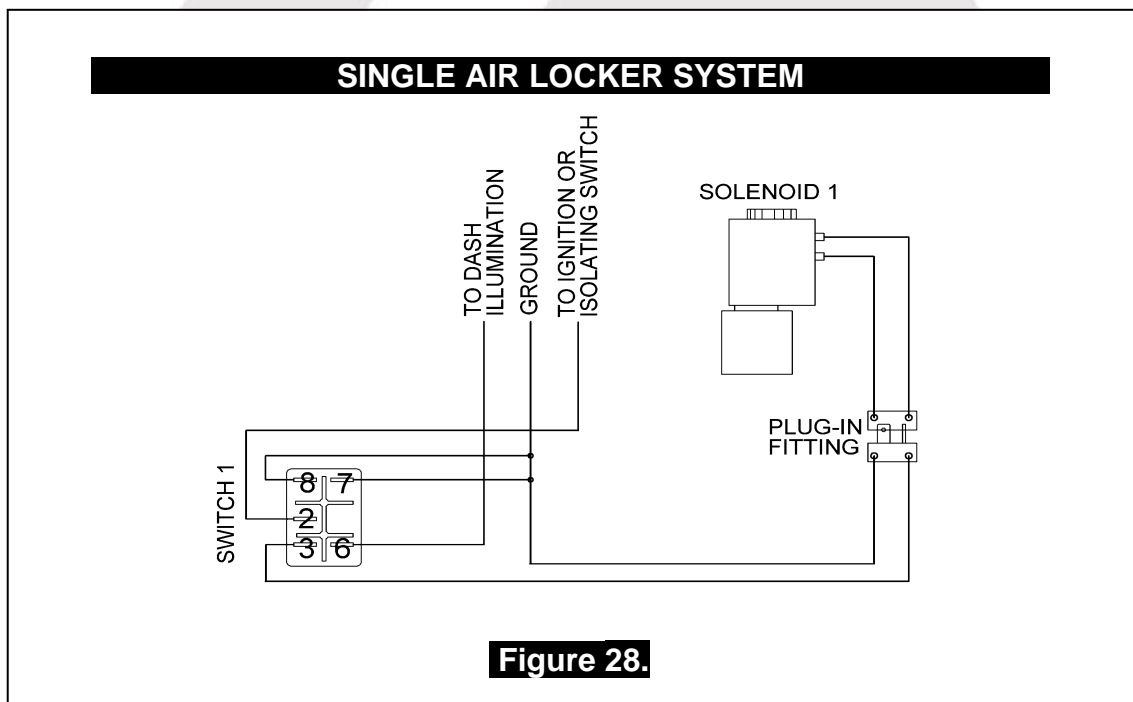

6 Testing & Final Assembly

6.1 Leak Testing

- With the vehicle parked and the engine off, turn the compressor on and wait until the air system is fully charged.

NOTE : With the *Air Locker(s)* disengaged, the air source (i.e., compressor) should not have to recharge over time. Intermittent recharging without *Air Locker* use usually indicates a leak at the solenoid fittings or at the compressor tank O-ring seal.

- Actuate the *Air Locker(s)*.
- The compressor should not come on again for a period of at least 15min. Air system recharging within that time period would indicate that a leak is present in the system.

NOTE : If an alternate air source (e.g., an air cylinder or a belt driven air pump) is used instead of a compressor, the air system will have to be leak tested with a pressure gauge and a shut-off valve in series before the solenoid input.

- If a leak is found to be present, spray a soap and water mixture onto all air fittings in the system while the compressor is fully charged. Bubbles should appear at any leak points.
- Check that leaky fittings have been adequately tightened.
- Disassemble, clean threads, and reapply thread sealant if leaking persists.

6.2 Testing the Air Locker Actuation

To test that your air system, electrical system, and your *Air Locker* differential is functioning correctly:

- Support the vehicle such that the wheels are free to rotate (e.g., on axle stands, a chassis hoist, etc.)
- Leave the parking brake off, the transmission in neutral, and the *Air Locker* switch 'OFF'.
- Turn the ignition to the 'ON' position (leaving the motor off). The large illuminating symbol on the *Air Locker* switch cover should be 'OFF'.
- Turn the compressor (or alternate air source) on to charge the air supply up to its maximum pressure.
- Rotate one wheel by hand. The wheel should rotate freely and the opposite wheel should be turning in the opposite direction without any resistance or mechanical noise from within the differential.

6 Testing & Final Assembly

- Turn the *Air Locker* switch to the 'ON' position. The illuminated symbol on the switch cover should light up.
- Rotate the same wheel again.
- Both wheels should rotate together.
- Turn the switch off again.
- Rotate the same wheel.
- The wheels should again rotate in opposite directions.

6.3 Re-Sealing & Filling the Differential

NOTE : Consult the *ARB Air Locker Operating & Service Manual* for recommendations on differential lubricant specifications.

- Refill the differential until level with the filler hole.
- Rotate the differential center 2 full turns.
- Check the oil level and refill if necessary.
- Replace filler plug (apply thread sealant to filler plug before inserting if it is a threaded type plug).
- Wipe differential housing clean of any oil or grease which may collect dirt or other abrasive particles.

6.4 Note For ADD Equipped Vehicles

IMPORTANT :

IFS vehicles equipped with Automatic Differential Disconnect (ADD) do not disconnect both wheels from the differential. Because of this, the internal gears of the differential of all ADD vehicles are in constant motion when moving in two wheel drive. For this reason, the front *Air Locker* in an ADD equipped vehicle **must never be engaged while moving in two wheel drive**, as doing so would cause any motion in the internal differential gears to be instantly transferred to your ring and pinion set, potentially causing extensive damage to your ring and pinion gears, your CV joints, and to your *Air Locker* differential. To eliminate this problem, save wear on your differential components, prolong the life of your CV joints, and increase your fuel mileage, ARB recommends that you eliminate the drag and wear in your front driveline components (which are not even being used in 2WD) by installing manual locking hubs, especially if your vehicle is used for extensive two wheel driving.

6 Testing & Final Assembly

6.5 Post-Installation Check List

Now that the *Air Locker* installation has been completed, ARB recommends that you take the time to complete the following check list just to insure that you haven't missed any of the vital steps.

- The air system has been leak tested.
- Thread locking compound was used on the ring gear bolts.
- All torque settings comply with the vehicle manufacturer's specs and were set with an accurate torque wrench.
- Differential fluid complies with ARB recommendations and has been filled to the correct level.
- All air lines and wiring have been securely cable tied to resist snagging.
- Switch(es) have been securely mounted within operator reach, yet well away from danger of accidental engagement.
- Switch(es) function correctly and illuminate to indicate that *Air Locker(s)* have been engaged.
- The *Air Locker* Warning Sticker has been located within close proximity of the actuator switch(es).
- All operators who are to use the *Air Locker* have read, and fully understand the *ARB Air Locker Operating & Service Manual*.

INSTALLATION PERFORMED BY: _____

DATE OF INSTALLATION: _____

ODOMETER READING: _____

AIR LOCKER SERIAL No.: _____



7 Parts List

RD90

TOYOTA 7.5" IFS

7.1 Exploded Assembly Diagram (see itemized parts list overleaf)

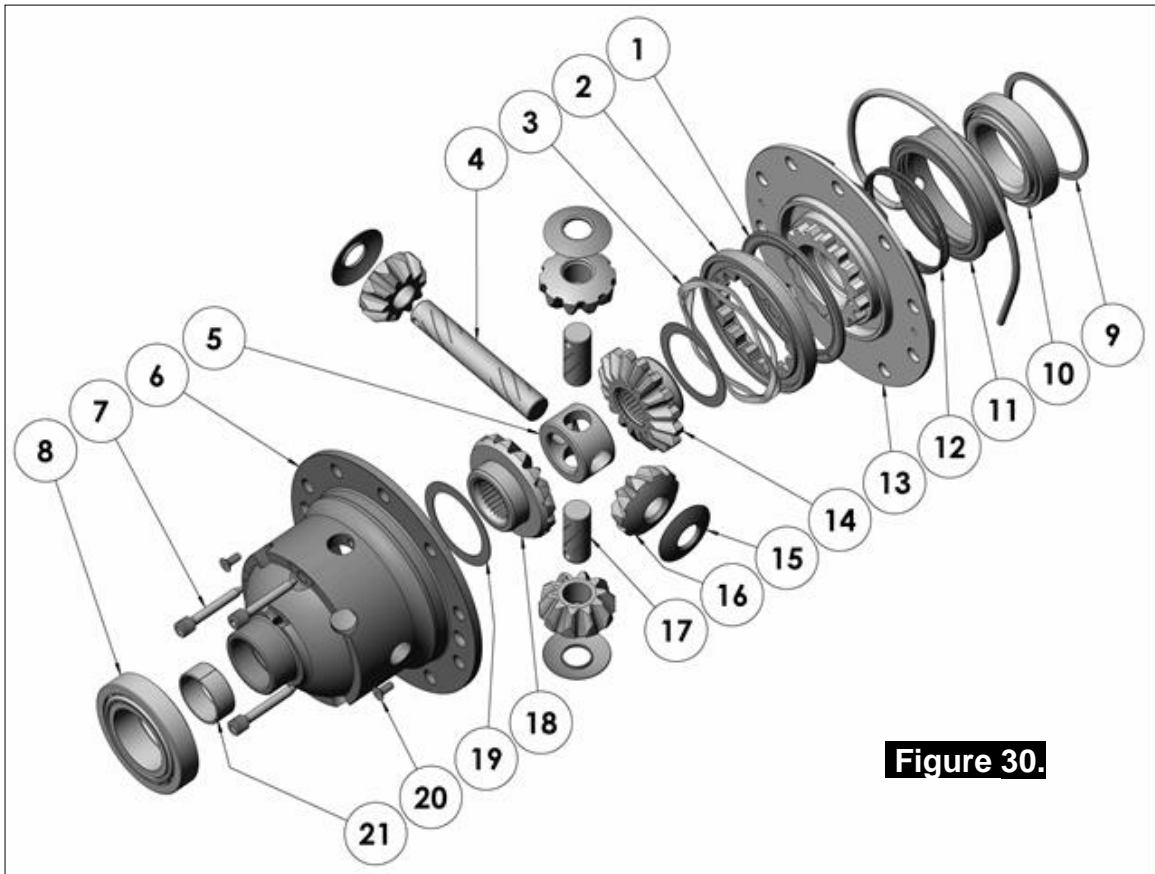

Figure 30.

7.2 Specifications

Axle Spline	27 tooth, Ø28.0mm [1.10"]
Ratio Supported	All
Ring Gear ID	118.0mm [4.65"]
Ring Gear OD	191mm [7.5"]
Ring Gear Bolts	10 bolts on Ø140mm [5.51"]
Ring Gear Torque	96Nm [71 ft-lb]
Backlash	0.13-0.18mm [0.005-0.007"]
Bearing Cap Torque	85Nm [63 ft-lb]

7 Parts List

7.3 Itemized Parts List

(see exploded diagram Fig.30.)

ITEM #	QTY	DESCRIPTION	PART #	NOTES
1	1	BONDED SEAL	160701SP	
2	1	CLUTCH GEAR & WAVESPRING KIT	050902SP	
3	1	WAVESPRING	150702SP	
4	1	LONG CROSS SHAFT	061302SP	
5	1	SPIDER BLOCK	070503SP	
6	1	DIFFERENTIAL CASE	013101SP	
7	1	RETAINING PIN SET (PK OF 4)	120601SP	
8	1	TAPERED ROLLER BEARING	NOT SUPPLIED	
9	1	SHIM KIT	SHK008	
*	1	MASTER SHIM	150320	
10	1	TAPERED ROLLER BEARING	160117	2
11	1	SEAL HOUSING KIT	081701SP	
12	1	SEAL HOUSING O-RINGS (PK OF 2)	160251-2	1
13	1	FLANGE CAP KIT	028501SP	
14	1	SPLINED SIDE GEAR	SEE NOTE	3
15	4	PINION THRUST WASHER	SEE NOTE	4
16	4	PINION GEAR	SEE NOTE	3
17	2	SHORT CROSS SHAFT	061402SP	
18	1	SIDE GEAR	SEE NOTE	3
19	2	SIDE GEAR THRUST WASHER	SEE NOTE	4
20	1	COUNTERSUNK SCREW (PK OF 2)	200213SP	
21	2	ANTI-FRICTION BUSHING (PTFE)	160801SP	
*	1	AIR LINE (6mm DIA X 6m LONG)	170314SP	5
*	1	BULKHEAD FITTING KIT (BANJO TYPE)	170114	5
*	1	SOLENOID VALVE (12V)	180103	
*	1	CABLE TIE (PK OF 25)	180305	
*	1	SWITCH FR LOCKER	180223	
*	1	OPERATING & SERVICE MANUAL	210200	
*	1	INSTALLATION GUIDE	210290	

* *Not illustrated in exploded view*

NOTES

- 1 For replacement O-rings use only BS149 Viton 75.
- 2 For replacement bearing use Timken part # LM503349 / LM503310.
- 3 Available only as complete 6 gear set # 728J021
- 4 Available only as complete thrust washer kit #730J01
- 5 All diffs produced before serial #17070001 came with 5mm air connection system.
For information contact ARB.
- Spare axle retaining clips may be required (not supplied) to refit CV shafts.

Part No. 210290
Revision 26/10/2020

Copyright © 2015 by ARB Corporation Limited

