



RD93

CHRYSLER 8¹/₄", 29 SPLINE

**AIR OPERATED
LOCKING DIFFERENTIAL
INSTALLATION GUIDE**

No liability is assumed for damages resulting in the use of the information contained herein.
ARB AIR LOCKER Locking Differentials and AIR LOCKER are trademarks of ARB Corporation Limited.
Other product names used herein are for identification purposes only and may be trademarks of their respective owners.

ARB 4x4 ACCESSORIES

Corporate Head Office

**42-44 Garden St
Kilsyth, Victoria
AUSTRALIA
3137**

**Tel: +61 (3) 9761 6622
Fax: +61 (3) 9761 6807**

**Australian enquiries
North & South American enquiries
Other international enquiries**

**sales@arb.com.au
sales@arbusa.com
exports@arb.com.au**

www.arb.com.au

Table of Contents:

1	Introduction	3
1.1	Pre-Installation Preparation	3
1.2	Tool-Kit Recommendations	4
2	Removing the Existing Differential	5
2.1	Vehicle Support	5
2.2	Differential Fluid Drain	5
2.3	Removing the Axles	5
2.4	Marking the Bearing Caps	6
2.5	Checking the Current Backlash Amount	7
2.6	Removing the Differential Carrier	8
3	Installing the Air Locker	10
3.1	Mounting the Ring Gear	10
3.2	Installing the Carrier Bearings	11
3.3	Drilling and Tapping the Bulkhead Port	12
3.4	Setting the Backlash	13
3.5	Profiling the Seal Housing Tube	14
3.6	Setting up the Bulkhead Fitting	16
3.7	Re-Installing the Axles	18
4	Installing the Air System	19
4.1	Mounting the Solenoid	19
4.2	Running & Securing the Air Line	21
4.3	Connection to the Bulkhead Fitting	22
5	Mounting & Connecting the Electrical System	23
5.1	Mounting the Actuator Switch(es)	23
5.2	Wiring the Actuator System	24
6	Testing & Final Assembly	27
6.1	Leak Testing	27
6.2	Testing the Air Locker Actuation	27
6.3	Re-Sealing & Filling the Differential	28
6.4	Post-Installation Check List	29
7	Parts List	31
7.1	Exploded Assembly Diagram	31
7.2	Specifications	31
7.3	Itemized Parts List	32



2 Removing the Existing Differential

IMPORTANT :

BEFORE ATTEMPTING TO DISMANTLE YOUR VEHICLE FOR THIS INSTALLATION, PLEASE READ THIS INSTALLATION GUIDE IN ITS ENTIRETY, AS WELL AS ALL APPLICABLE SECTIONS OF YOUR VEHICLE MANUFACTURER'S SERVICE MANUAL.

1.1 Pre-Installation Preparation

This booklet is to be used in conjunction with your vehicle manufacturer's service manual. ARB endeavors to account for every possible variation in vehicle model when publishing its installation guides, and guides are updated regularly as new model information becomes available, however, the rapid and globally varied release of some vehicles makes it difficult to insure that your vehicle model has been accurately accounted for. In the case of any technical discrepancies between this guide and your service manual, we strongly advise that you adhere to the specifications and techniques as documented in your service manual.

Although your *ARB Air Locker* comes complete with all the step by step instructions you will need to supplement your vehicle manufacturer's service manual and install your new differential, ARB recommends that you have your *Air Locker* installed by a trained professional. Many ARB distributors around the world have been fully instructed in *Air Locker* installations by ARB, and have gained a wealth of experience and skill from years of performing similar installations.

Once you begin this installation your vehicle will be immobile until all steps of the installation are complete. Make sure your *Air Locker* kit is the correct model for your vehicle and that it contains all of the parts listed on back cover of this booklet. Also be sure you have appropriately equipped yourself with all the necessary tools, parts, and materials to complete this installation (see Section 1.2 *Tool-Kit Recommendations*), and that you have allowed for an appropriate amount of vehicle down time.

HINT :

Place a ✓ mark inside each of the □ symbols as you complete each step. It is very important NOT to miss any of the steps!

2 Removing the Existing Differential

1.2 Tool-Kit Recommendations

Below is a list of tools and supplies you may need to complete this installation. Requirements for your vehicle may vary. Please consult your vehicle service manual for additional recommendations.

1.2.1 Tools

- Standard automotive sizes (metric and/or imperial) of sockets, wrenches, Allan keys, and drills.
- A dial indicator or other suitable measuring tool for checking ring & pinion backlash.
- A razor knife for nylon tubing.
- A suitable adjuster nut wrench to set backlash and preload for your model of axle assembly.
- A torque wrench (See vehicle service manual for required torque range)
- A lubricant drain reservoir.
- A 11.2mm [7/16"] drill and 1/4"NPT tap for bulkhead fitting installation.
- Needle-nosed pliers.
- An automotive bearing puller (2 jawed) or a differential carrier bearing puller.
- A bearing press or arbor press.

1.2.2 Supplies

- Thread lubricant/sealant compound (e.g., LOCTITE #567)
- Thread locking compound (e.g., LOCTITE #272)
- A gasket sealant or replacement gasket for your differential cover.
- A sufficient volume of differential oil to completely refill your housing. (see the *ARB Air Locker Operating and Service Manual* for recommended lubricants)
- A soap and water mixture to test for air leaks.
- Teflon paste.

2 Removing the Existing Differential

2.1 Vehicle Support

- Safely secure the vehicle on a hoist. We recommend supporting the vehicle on a chassis hoist to keep the differential area at a convenient working height and to leave the wheels and axles free to be rotated and removed.
- Once supported in the air, release the parking brake and leave the vehicle in neutral. Chock the wheels if necessary.

2.2 Differential Fluid Drain

- Clean around the differential cover seal to prevent dirt from entering the differential.
- Position a fluid drain reservoir under the differential.
- If a drain plug exists, remove it and completely drain all differential oil from the housing.
- If no drain plug exists then the oil can be drained by loosening the cover bolts and gently prying the cover away at the bottom until oil runs out.

HINT : If no drain plug exists then it would be a good idea to drill and tap for a tapered oil drain plug to assist with future oil changes.

- Once drained, remove the differential cover plate.

HINT : This is a good time to check for metal particles in your oil and in the bottom of the housing which may indicate a worn bearing or differential component.

2.3 Removing the Axles

IMPORTANT :

Collision damage or heavy off-road use of your vehicle in the past may have resulted in some degree of bending in the axle. Any misalignment of the axle tubes may result in excessive wear and/or failure of your differential and axle shafts. ARB strongly recommends that you have your axle assembly inspected for concentricity and straightness before installing your *Air Locker*.

2 Removing the Existing Differential

- Remove the wheels and brake assembly according to your vehicle's service manual.
- Rotate the differential center until the cross shaft can be removed.
- Remove the cross shaft retaining pin and the cross shaft.
- Rotate the differential until the 'C' clip access window is accessible.
- Gently tap the axle ends inward to release the 'C' clips.
- Remove 'C' clips with needle nose pliers.
- Gently tap axles outward and remove them from the differential center.

NOTE : Rubber oil seals can be easily damaged. Support the weight of the axle when extracting it across the edges of the seals.

2.4 Marking the Bearing Caps

- Using a small pointed center punch, gently mark the left bearing cap in a way which will enable you to know which cap is 'LEFT' and 'RIGHT', and which way is 'UP' and 'DOWN'. (Fig.1.)
- Mark the right hand cap in a similar way.

HINT : Many installers choose to make one punch mark on the left hand side of the left hand bearing cap and a similar mark on the housing at close proximity to the cap mark. The right hand side is then designated with two punch marks on the right hand side of the cap and two similar punch marks on the housing.



Figure 1.

2 Removing the Existing Differential

2.5 Checking the Current Backlash Amount

IMPORTANT:

This step is a precautionary measure recommended by ARB due to the fact that some after market ring and pinion sets have been manufactured to run with different backlash settings than those specified by your vehicle manufacturer. Although ARB must recommend you set backlash according to your service manual guidelines, we also advise that you compare the backlash measurements taken here to the recommended backlash settings in your vehicle service manual. Measurements found to be outside of your service manual recommendations may indicate the need to deviate from those settings in order to achieve quiet running with a good contact mark.

Refer to your vehicle service manual or your local authorized ARB installer for more information.

- Set a depth indicator on one of the ring gear teeth as in Figure 2.

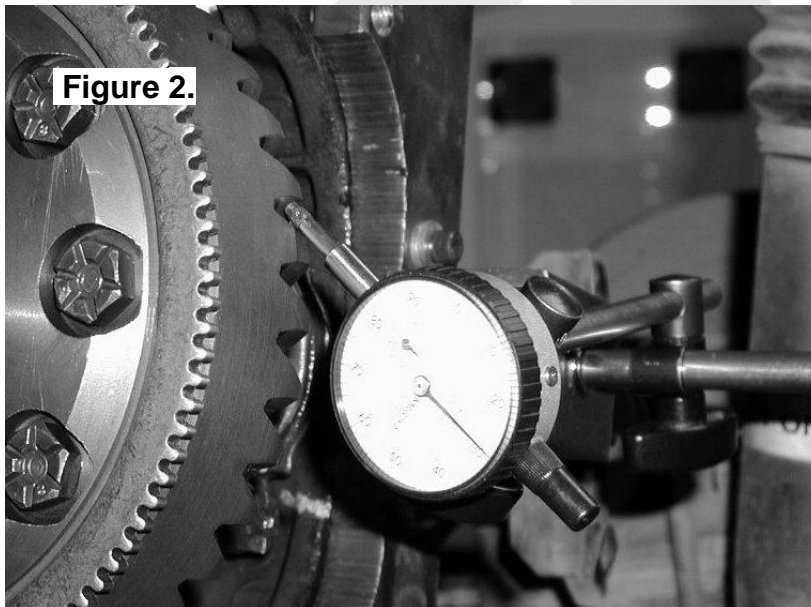

- While supporting the pinion gear by holding the drive shaft, rotate the differential in both directions while observing the maximum variation in depth from the indicator (i.e., the highest value minus the lowest value). This value is referred to as the ring and pinion backlash.
- Rotate the differential center 90° and measure again for accuracy.
- Record the average of all measurements.

2 Removing the Existing Differential

2.6 Removing the Differential Carrier

- Remove the adjuster nut locking tabs.
- Remove the bearing caps from the third member.
- Remove the adjuster nuts.
- Carefully remove the differential carrier from the third member.

NOTE : The differential center is heavy and quite difficult to handle when covered in oil. Do not drop it!

- Remove the tapered roller bearings from the differential carrier with a bearing puller. (Fig.3.)

HINT : Check the condition of the bearing for wear and discard if damaged.



- Secure the original differential to a work bench.
- Remove the bolts that hold the ring gear in place.

NOTE : Chrysler 8.25" ring gear bolts are usually left hand threaded.

- Using a plastic or copper hammer, tap in a circle around the ring gear to separate it from the differential carrier.

2 Removing the Existing Differential

IMPORTANT:

Some Salisbury axles were manufactured with poor oil drainage between the axle tubes and the differential housing. This can often result in one of the axle tubes filling up with differential oil while running. In most cases this will result in a blocked air vent which will cause the differential housing to pressurize and expel oil from the axle seals at the wheels or force oil into the air system of the *Air Locker*, eventually expelling oil at the solenoid valve. This is a design flaw which was corrected by most automakers in the later releases of their axle assemblies. If no lower drainage point is present in the differential housing then it is critical that you modify the housing to include one.

- Inspect the differential housing for the presence of adequate drainage in both axle tubes (refer to Fig.4.).

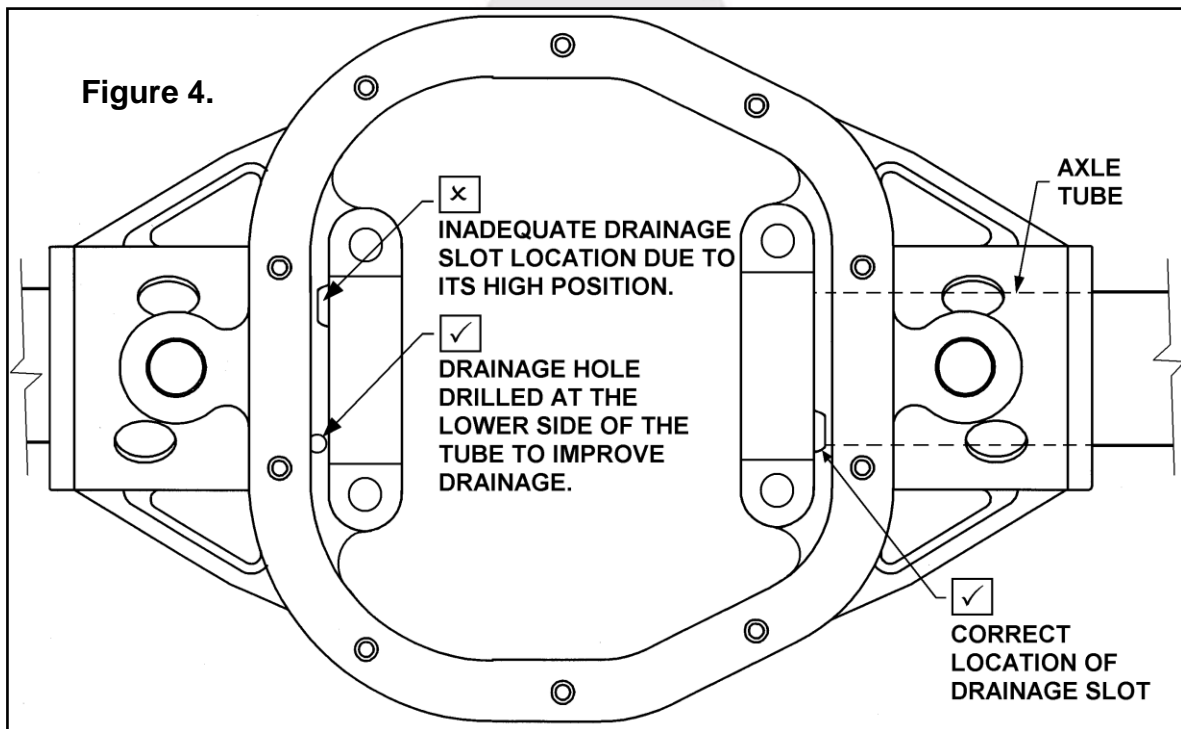

- If drainage is inadequate or does not exist then a slot or hole should be cut into the housing on the lower side of the tube(s) to allow oil out of the axle tube area.

NOTE : Make sure any grinding dust, filings or drill chips left behind by cutting the drainage slots is completely cleaned out of the housing.

- Check that the axle air vents are clear and working correctly.

3 Installing the Air Locker

3.1 Mounting the Ring Gear

IMPORTANT:

Higher ratio gearing uses deeper (thicker) ring gears with teeth that extend much further. Make sure the teeth of the ring gear will not obstruct the removal of the cross shaft when fitted. If so, ARB recommends that you grind just enough off of one of the ring gear teeth to successfully remove the cross shaft.

DO NOT MODIFY THE CROSS SHAFT!

IMPORTANT:

Newer OEM Chrysler 8.25" ring and pinion sets use 7/16" bolts. The flange holes of the *Air Locker* must be reamed from Ø3/8" to Ø7/16" to suit.

NOTE : If your existing differential was fitted with a toner ring it will need to be removed and installed onto the *Air Locker* before the ring gear can be mounted. See your vehicle service manual.

- Apply a thin film of high pressure grease to the ring gear shoulder of the *Air Locker* to prevent seizing.
- Thoroughly clean any thread locking compound or other foreign matter from the holes of the ring gear, the threads of the ring gear bolts, and the mating surfaces between the ring gear and the *Air Locker* flange.

HINT : Stoning the ring gear mounting face before installation will remove any high spots around the threads.

- Heat the ring gear to between 80 and 100°C [175 - 212°F] in hot water or in an oven to slightly expand the gear and facilitate assembly.

NOTE : **NEVER HEAT GEARS WITH A FLAME!** This could damage the hardened surface of the gear and result in premature wear or failure.

- Dry the gear and bolt holes with compressed air (if wet).
- Install the ring gear onto the *Air Locker* by aligning the bolt holes and then gently tapping it around in a circle with a soft mallet. Avoid using the bolts to pull down the ring gear as this puts excess strain on the bolts and the differential flange.

3 Installing the Air Locker

- Apply a thread locking compound to the thread of each ring gear bolt before inserting it. Do not apply threading compound directly into the threaded hole as this could prevent the bolt from reaching its full depth.
- Tighten the ring gear bolts in a star pattern with a torque wrench according to your vehicle manufacturer's specified torque.

3.2 Installing the Carrier Bearings

- Apply a thin film of high pressure grease to the bearing journal of the *Air Locker*.
- Using a bearing press or arbor press, press one of the bearing cones which was removed from the original differential onto the bearing journal (refer to Figure 5.) until the bearing seats firmly against the bearing journal shoulder.

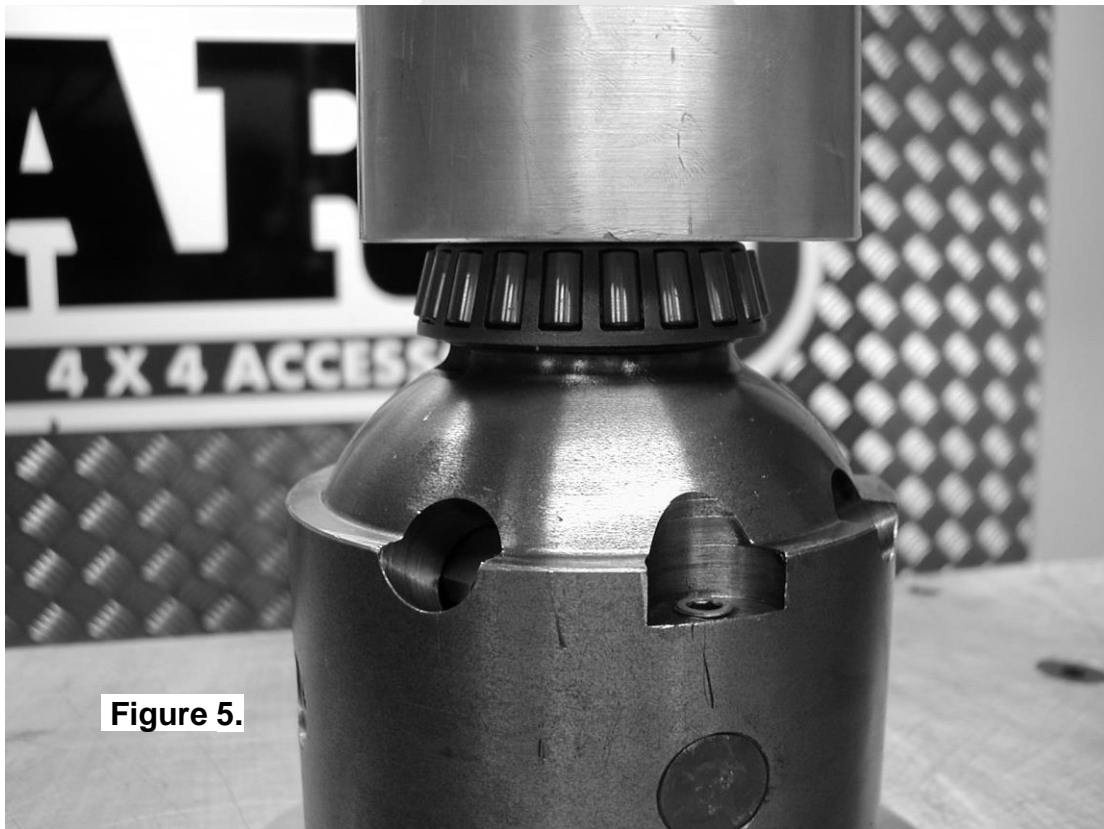

Figure 5.

NOTE : Never re-use any bearings which are damaged or worn.
Do not bend or damage the seal housing tube.

3 Installing the Air Locker

3.3 Drilling and Tapping the Bulkhead Port

An airline port must be drilled and tapped through the differential housing to mount the bulkhead fitting into.

- Mark a spot on the top of the outside shell of the differential housing that will be clear of the ring gear position once the seal housing tube has been installed. Figure 6. shows how the tube will port through the differential housing.

NOTE : Higher ratio gearing uses deeper (thicker) ring gears with teeth that extend much further. Make sure the intended hole location is far enough away from the ring gear teeth that the air line will not be at risk of contact with the current or future ring gears.



Figure 6.

- Cover the drive pinion and axle tube areas with a rag to protect them from metal filings.
- Drill through the housing square to the outside surface using a 11.2mm [7/16"] drill. (Figure 7.)



Figure 7.

3 Installing the Air Locker

- Tap the hole from the outside using a 1/4" NPT pipe tap.
- Remove any sharp edges from the hole that may chip-off and fall into the housing.
- Carefully remove rags and inspect with a service light inside the housing to insure no metal filings are left behind.

3.4 Setting the Backlash

- Hold the bearing cups onto the *Air Locker*, insert it into the housing and rotate it until it is fully in mesh with the pinion gear.
- Sit the adjuster nuts into the threads against the bearing cups.
- Install the bearing caps (use the markings from Section 2.4 to determine which side is which) and hand tighten all bearing cap bolts lightly.
- Hand tighten both adjuster nuts against the *Air Locker* until only a small amount of backlash can be felt.
- Set a depth indicator on one of the ring gear teeth as in Figure 8.
- While supporting the pinion gear by holding the drive shaft, rotate the differential in both directions while observing the maximum variation in depth from the indicator (i.e., the highest value minus the lowest value). This value is referred to as the ring and pinion backlash.
- Rotate the differential center 90° and measure again for accuracy.



Figure 8.

3 Installing the Air Locker

- Refer to your vehicle service manual for the specified maximum and minimum amounts of backlash.
- Adjust the backlash using an adjuster nut wrench to tighten or loosen the adjuster nuts as required.
(Refer to your vehicle service manual.)
- Recheck backlash as before, repeating this procedure until backlash is within the specified amount.

IMPORTANT:

It is critical to set up bearing pre-load when a differential is installed. Improper pre-load will result in undue bearing wear, increased stresses in the differential center, increased running noise, and ultimately, ring and pinion gear damage.

- Set pre-load by tightening the adjuster nuts against each other by an amount specified in your vehicle service manual.
- Tighten the bearing cap bolts with a torque wrench to the torque specified in your vehicle manufacturer's service manual.
- Install locking tabs onto the bearing caps.

3.5 Profiling the Seal Housing Tube

- Without using sharp, jagged tools such as pliers (usually your hands are the best tool for this job), bend the seal housing tube so that it runs under the ring gear and upwards protruding through the bulkhead port in the differential housing. (Fig. 9. & Fig. 10.)
- Check that the contour of the tube will not interfere with the *Air Locker* or the ring gear.

NOTE : It is a good idea to keep the tube away from the bearing caps or any other part of the differential casting as any contact due to vibration or shock may wear the tube and eventually cause a leak.

3 Installing the Air Locker

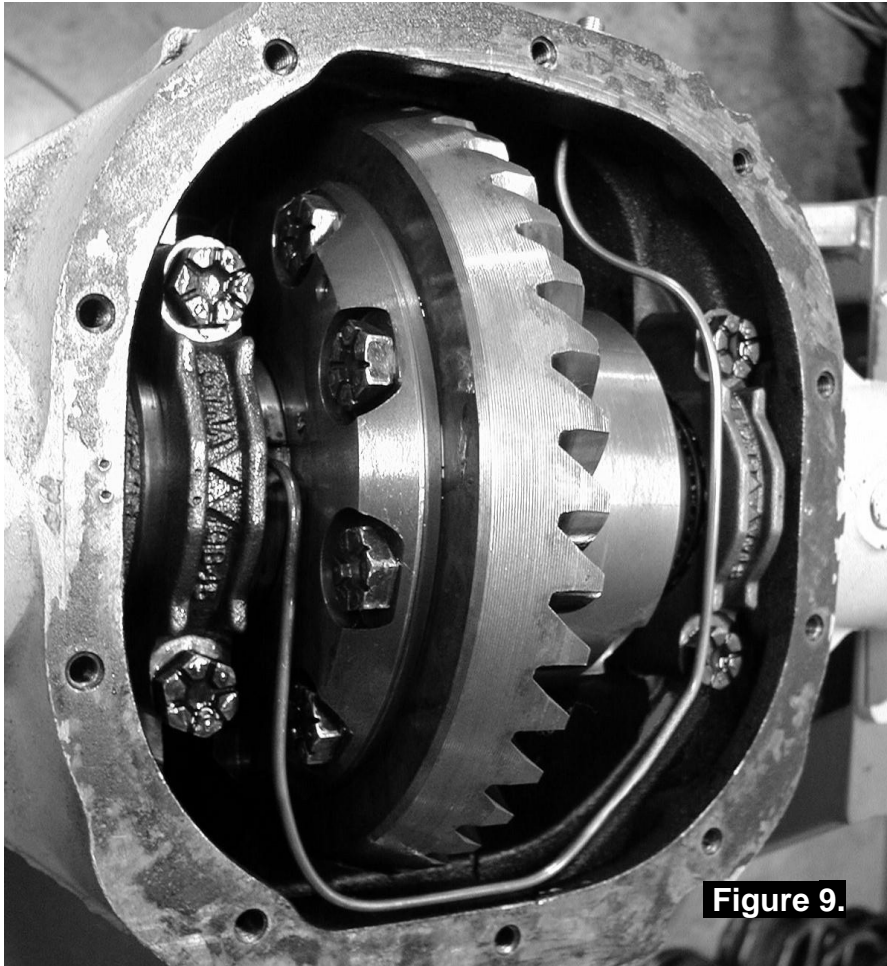

Figure 9.

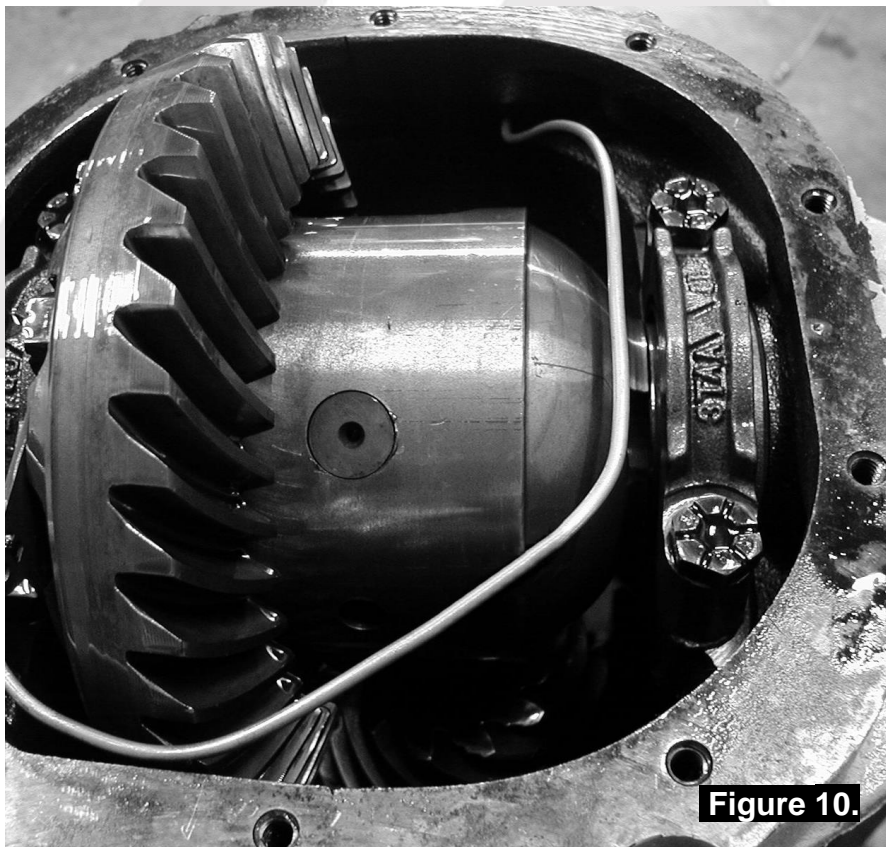

Figure 10.

3 Installing the Air Locker

3.6 Setting up the Bulkhead Fitting

- Trim the seal housing tube that is extended outside the differential housing to approximately 20-25mm [0.8-1.0"] of extension using an automotive brake line tubing cutter.

NOTE : Never use a hacksaw for trimming the steel tube as this will leave metal fillings in the air system.

- Apply thread sealant to the outside threads of the bulkhead body.
- Screw the bulkhead body into the tapped hole, and lightly tighten using a 14mm [9/16"] spanner.
- Wipe the area clean of any excess thread sealant (inside and outside of the housing).
- Insert the free end of the seal housing tube into the bulkhead fitting until it protrudes approximately 8mm [5/16"] through the other side.
- From the outside of the housing, assemble one of the small O-rings over the top of the short length of seal housing tube protruding through the bulkhead fitting.
- Install the brass spacer.
- Install the second small O-ring after the spacer.
- While holding the seal housing tube into the bulkhead fitting, insert the chamfered end of the center compression nut over the extended tube as shown in the assembly diagram (Fig. 11.), and screw it into the bulkhead body, and tighten using Pozidriv #3 screwdriver.

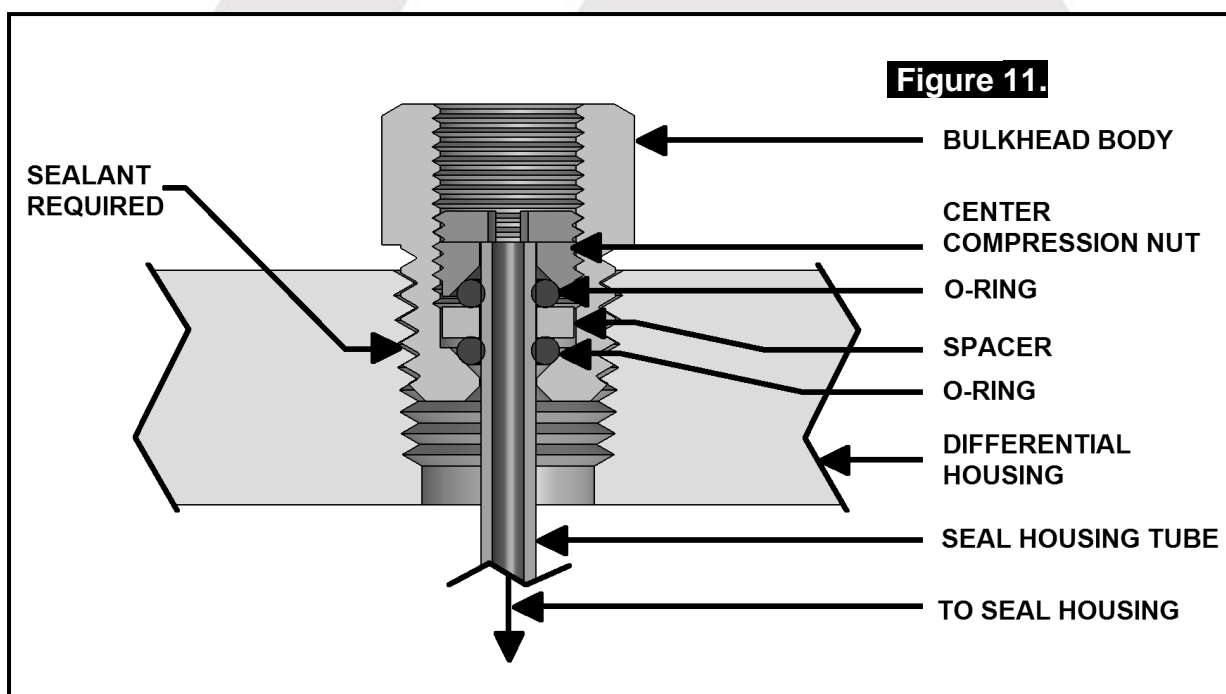

3 Installing the Air Locker

NOTE : Make sure the seal housing tube is all of the way into the center compression nut while you are tightening it.

NOTE : Firmly tighten the center compression nut so that a good seal is formed around the tube.

- Again check that no part of the seal housing tube comes in contact with the moving differential components. Less than 8mm [5/16"] should be considered too little clearance. Gently bend the tube away from moving parts if necessary.



3 Installing the Air Locker

3.7 Reinstalling the Axles

- Unscrew and remove the long cross shaft retaining pin with a 5mm hex key.

NOTE : The long cross shaft retaining pin is the pin located exactly one quarter turn of the differential from the 'C' clip access window. Rotate the differential using the drive flange.

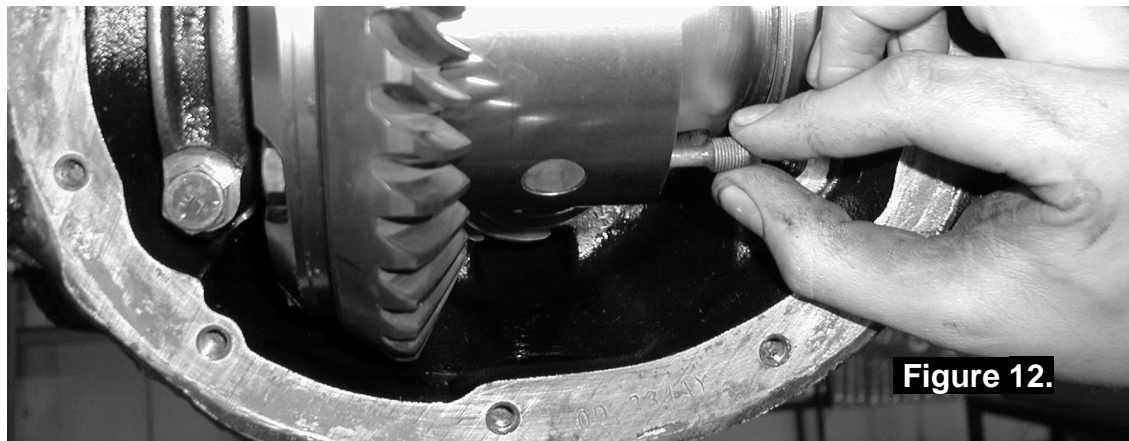

- Completely remove the long cross shaft.
- Rotate the differential center until the 'C' clip access window in the differential is in view and accessible.
- Insert both axles fully into the housing and gently tap them inward.

NOTE : Be careful not to damage oil seals with the axle.

- Install the 'C' clips on to the ends of the axles.
- Gently tap the axles outward until both 'C' clips are fully seated.
- Insert the cross shaft maintaining alignment between the cross shaft retaining pin hole in the differential and its corresponding hole in the cross shaft.
- Ensure that some degree of axle end float exists (i.e., some clearance exists between the end of the axle and the cross shaft or thrust block). 'C' clips may need to be substituted with others of a different thickness to achieve correct end float if too tight or too loose. Refer to your vehicle manufacturer's service manual for the procedure on setting up the correct end float condition.
- Insert and tighten the pin with a 5mm hex key.
- Reassemble brakes and wheels according to your vehicle's service manual.

4 Installing the Air System

4.1 Mounting the Solenoid

4.1.1 Connection to an ARB Air Compressor (Fig.13.)

- Remove one of the 1/8" BSP plugs from its port in the compressor tank.
- Apply Teflon paste to the 1/8" BSP nipple on the solenoid and insert it into the port and tighten. The solenoid should be rotated into a position which does not obstruct any other ports on the compressor tank.

NOTE : The coil and stem of the solenoid can be removed to make installation easier.

NOTE : The solenoid is marked with two #1 ports. If space is tight, a second solenoid can be "daisy-chained" off the first one by removing the plug from the redundant #1 port and screwing the nipple from the second solenoid into it (Fig. 13.).

NOTE : The solenoid exhausts compressed air through the center of the black retaining cap when the *Air Locker* is disengaged. Make sure this orifice cannot be obstructed.

- Assemble the 6mm push-in fitting into the solenoid outlet port (stamped "2") and hand tighten.

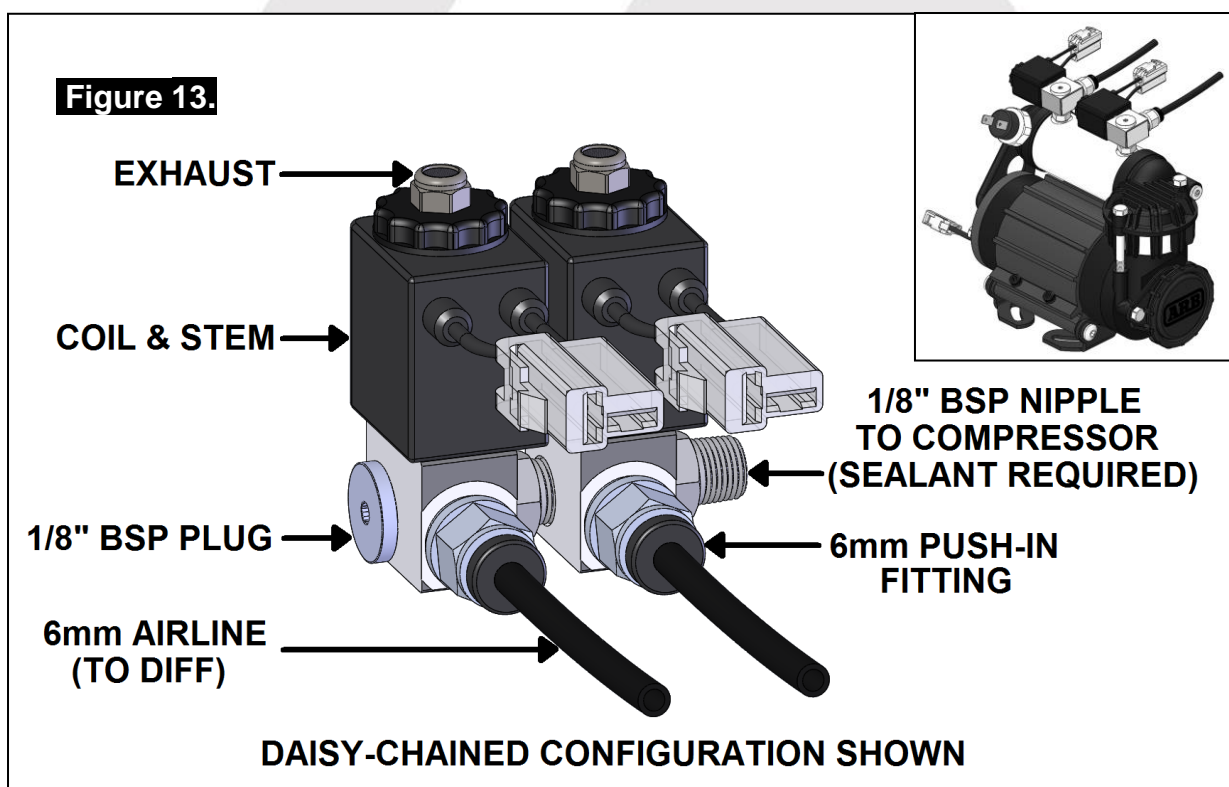

4 Installing the Air System

4.1.2 Connection to an Alternate Air Source

For ease of installation, quality of air supply, and a high level of dependability from your *Air Locker(s)*, ARB strongly recommends use of a genuine *ARB Air Compressor*, however, the *Air Locker* air system can be operated on any alternate air source that meets each of the following guidelines:

- Must supply a minimum of 85PSI [586kPa].
- The air source should have a tank capacity which enables it to actuate the *Air Locker(s)* in one charge so that no hesitation is experienced when locking one or two differentials.

HINT : A good way to insure that you have the necessary capacity is to make sure you can engage, disengage, and then reengage your *Air Locker(s)* without the air source having to regenerate (e.g., without the compressor turning on to refill the tank).

- Must supply clean air, free of rust, dirt, water, or other foreign matter.
- Must match the 1/8" BSP porting of the *Air Locker* solenoid.
- Mount solenoid within close proximity of the air supply and secure it from the effects of vibration and shock.
- Connect the air supply to the 1/8" BSP inlet port of the solenoid (stamped "1" on the solenoid body) using thread sealant.

IMPORTANT :

ARB cannot warranty your *Air Locker(s)* against damage caused as a result of using an alternate air supply. If you have any doubts as to the suitability of your air system to use in an *Air Locker* system, consult your ARB distributor.

4 Installing the Air System

4.2 Running and Securing the Air Line

The path taken by the air line from your air source (i.e., compressor) to your *Air Locker* is unique to your vehicle and the position of your air source. Plan ahead carefully when running the air line and always follow these guidelines:

- Account for axle travel when running the line from the axle to a fixed point on the vehicle. Leave enough slack in the air line to allow for maximum suspension travel in both directions.
- Avoid leaving large lengths of air line hanging underneath the vehicle where they may get tangled on rocks, sticks, etc.

HINT : Cable tying the air line to one of your flexible brake lines will account for axle travel and should help keep your line from getting snagged.

- Run the air line all the way from the compressor to the differential before trimming either end of the line to length. This will save complications which may arise if the air line has to be removed.
- Make sure the line does not contact sharp edges or abrasive surfaces that may damage the air line over time.
- Do not run the air line around tight bends which may kink the air line and restrict or block the air flow.
- Keep the air line well away from your vehicle's exhaust components. Air lines will melt if subjected to extreme heat.
- Do not run more air line than necessary. Excess line volume created when coiling the left over hose, using unusually large diameter hose, etc., will increase drain on the compressor tank resulting in the compressor running more often than needed.
- Support the air line by tying it back with cable ties wherever possible.
- At the solenoid end of the air line, trim the line to length with a sharp knife.
- To attach the air line to the push-in fitting of the solenoid; insert the line firmly into the fitting, pull outward on the flange of the fitting while holding the line as far into the fitting as possible, and then gently pull outward on the air line to clamp the line in place.

NOTE : To remove the air line from the push-in fitting; pull outward on the flange of the fitting, push the air line as far into the fitting as possible and hold, push inward on the flange, and then pull the air line free of the fitting.

4 Installing the Air System

4.3 Connection to the Bulkhead Fitting

- Trim the air line to length using a sharp knife.
- Assemble an aluminium washer onto the banjo bolt and insert through the banjo fitting. Assemble second aluminium washer and tighten into bulkhead fitting using a 14mm [9/16"] spanner. (Fig. 14.)
- Apply thread sealant to the tapered thread of the compression fitting body and screw into the banjo fitting. Tighten using a 12mm spanner.
- Insert the outer compression nut and ferrule over the air line. Ferrule should be orientated as per Fig.14.

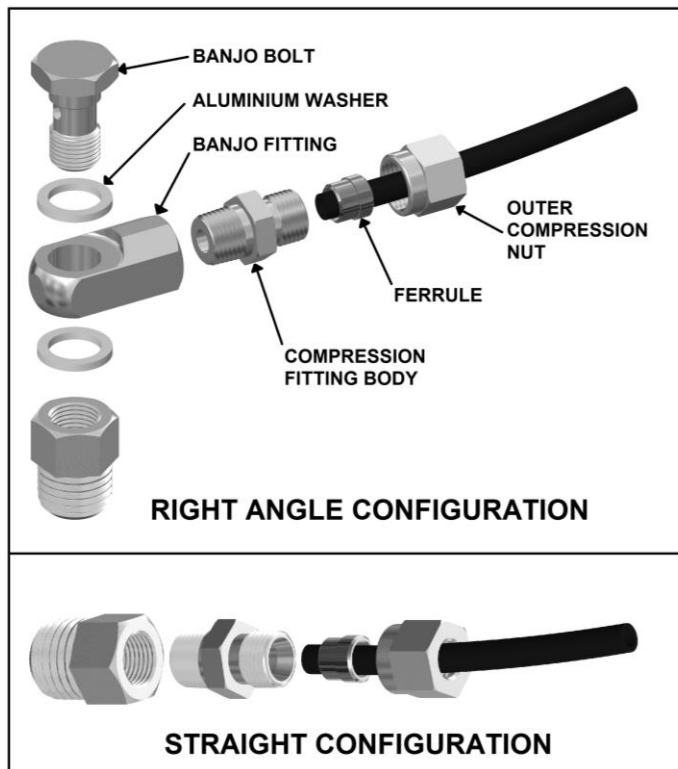

Figure 14.

- Push the airline into the compression fitting body and screw the outer nut down onto it. Using a 12mm spanner, tighten the outer nut onto the compression fitting body.

NOTE : Some force is required to crush the ferrule, however the outer compression nut will tighten against a stop. Over tightening will not create a better seal.

- Secure any loose sections of tube with a cable tie.

NOTE : When right angle routing of the tube is not required, screw the compression fitting body straight into the bulkhead fitting body (Fig.14.).

5 Mounting & Connecting the Electrical System

5.1 Mounting the Actuator Switch(es)

Air Locker actuator switch(es) can be easily panel mounted inside the vehicle in a 21mm x 36.5mm [0.83" x 1.44"] rectangular cutout.

NOTE : Only attach the cover plate to the face of the switch once the switch has been mounted and wired correctly as the cover plates are designed to be difficult to remove.

For reasons of safety and for ease of operation, the *Air Locker* actuator switch(es) should be mounted in a location picked to best suit the operator. Make sure you have taken the following points into consideration:

- Switch(es) **MUST** be mounted and should never be allowed to simply dangle from the wiring loom during vehicle use.
- Switch(es) should be within easy reach of the driver. Ideally, any *Air Locker* switch should be able to be operated without physical effort or distraction to the driver. Switch(es) should be mounted within the line of sight of the driver so that switch position ('ON' or 'OFF') can be visually determined by the rocker position and the illumination state.
- The position of the switch(es) should best eliminate any possibility of accidental operation by the driver or one of the passengers.
- Switch cutout position(s) must be located in an area with a minimum of 50mm [2"] of clearance behind the face of the cutout
- Switch(es) should not be mounted where they will be exposed to water (e.g., in the lower section of an inner door panel).
- ARB recommends that you apply the *Air Locker* warning sticker (ARB part # 210101) within close visual proximity of the switch location.

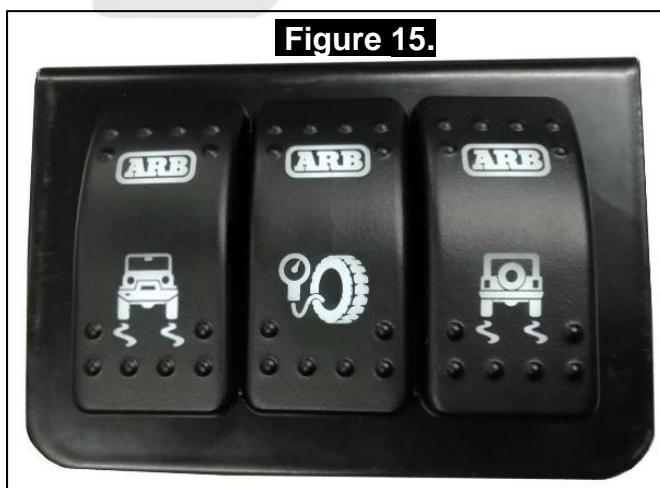

NOTE :

If no adequate position can be found on existing dashboard panels, a surface mounted bracket (Fig. 15.) may be purchased from your *ARB Air Locker* distributor to suit 1, 2, or 3 switches.

5 Mounting & Connecting the Electrical System

5.2 Wiring the Actuator System

5.2.1 Connection to an ARB Air Compressor

When wiring the *Air Locker* actuator switch(es) and solenoid(s) to an *ARB Air Compressor*, all connections can easily be set up directly from the supplied wiring loom (Fig.16.).

NOTE : 180409 model loom shown for reference only. Refer to your **ARB Air Compressor Installation Guide** for details on configuring your installation.

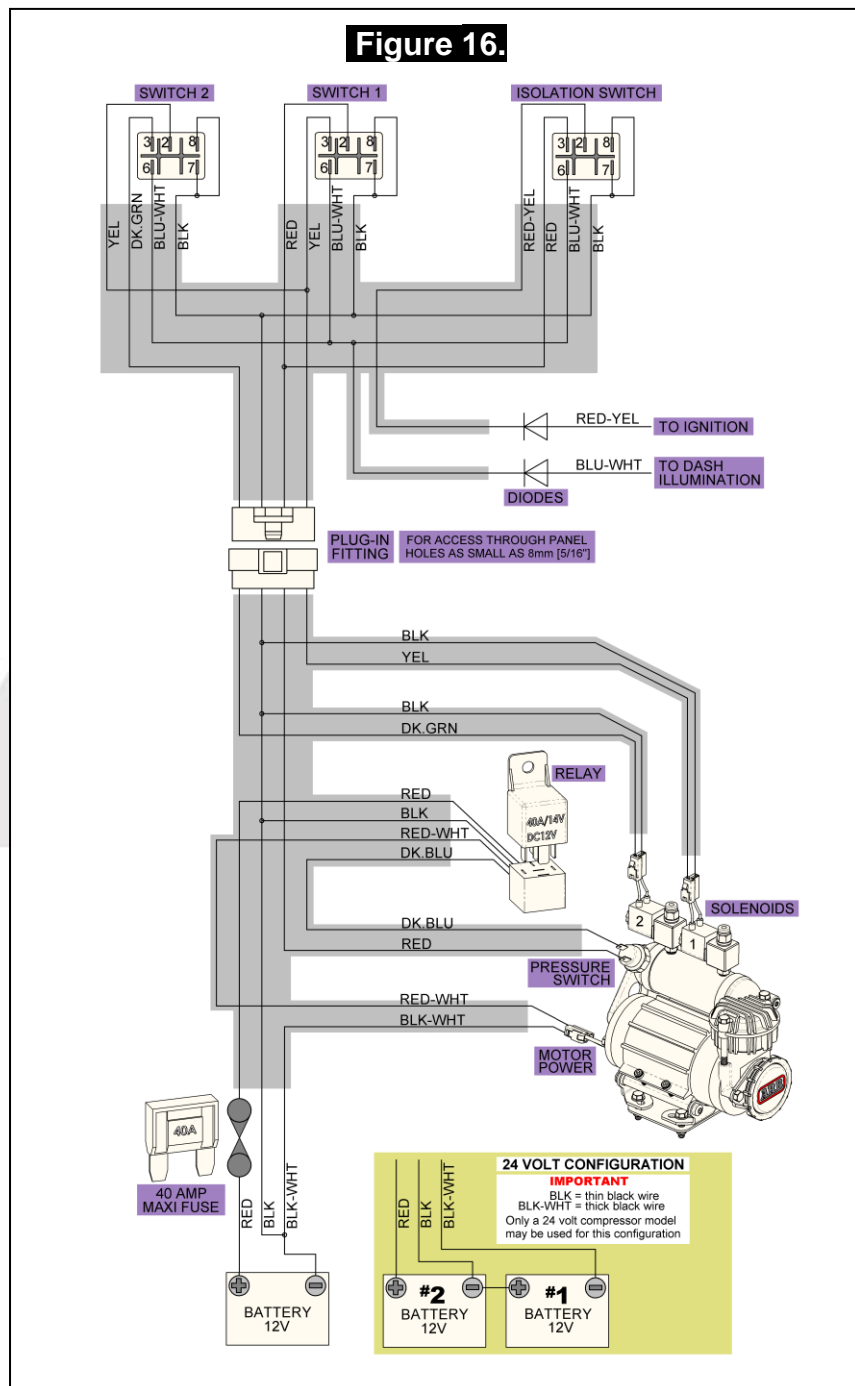

5 Mounting & Connecting the Electrical System

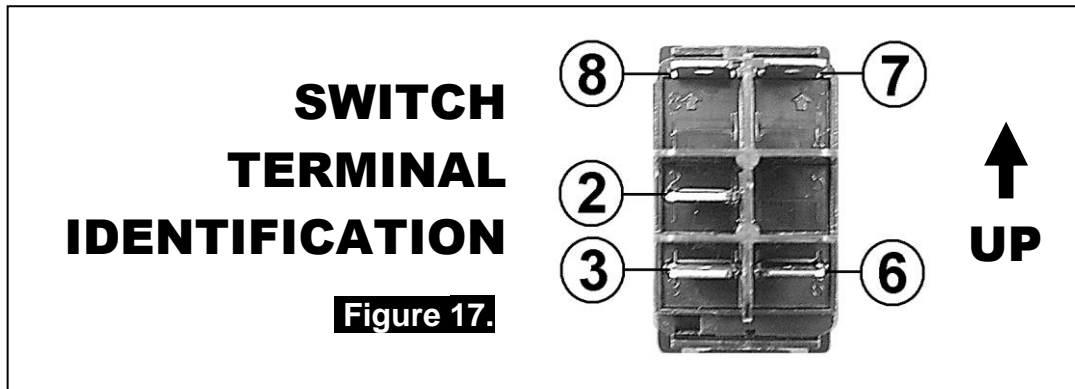

5.2.2 Connection to an Alternate Air Source

When connecting the actuation switch to an alternate air source, the switch(es) should be wired according to Figures 18. and 19., depending on whether one or two *Air Lockers* will be installed in the vehicle.

5.2.2.1 Single Air Locker System

- If only one *Air Locker* is to be installed in the system, the switch and solenoid should be wired according to Figure 18. regardless of whether the *Air Locker* has been installed in the front or rear axle of the vehicle.
- Attach the appropriate switch cover (i.e., 'FRONT' or 'REAR') to the switch.

NOTE : Refer to Figure 17. for the correct switch terminal identification and switch orientation.

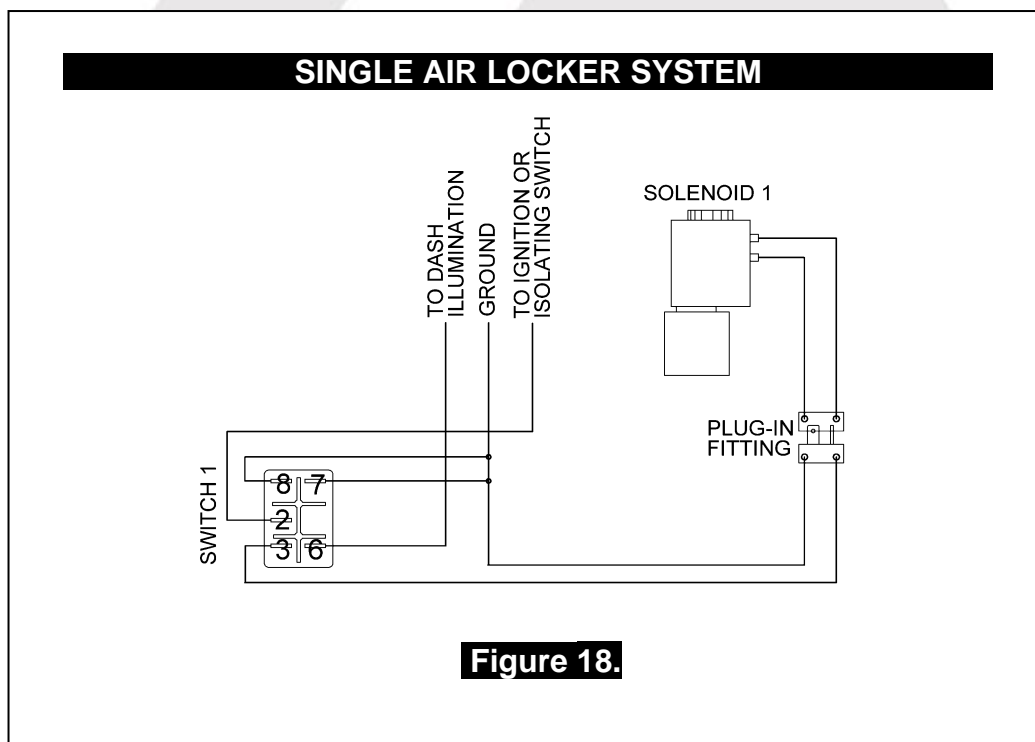

5 Mounting & Connecting the Electrical System

5.2.2.2 Dual Air Locker System

- If two *Air Lockers* are to be installed in the system, ARB recommends that the switches and solenoids be wired according to Figure 19. For safety reasons, this configuration allows SOLENOID 2 to be actuated only if SOLENOID 1 is already on.
- Attach the “REAR AIR LOCKER” switch cover to SWITCH 1, and the “FRONT AIR LOCKER” switch cover to SWITCH 2.

NOTE : Refer to Figure 17. for the correct switch terminal identification and switch orientation.

- Configure SOLENOID 1 as the air line leading to the rear axle *Air Locker*, and SOLENOID 2 as the air line leading to the front axle *Air Locker*.

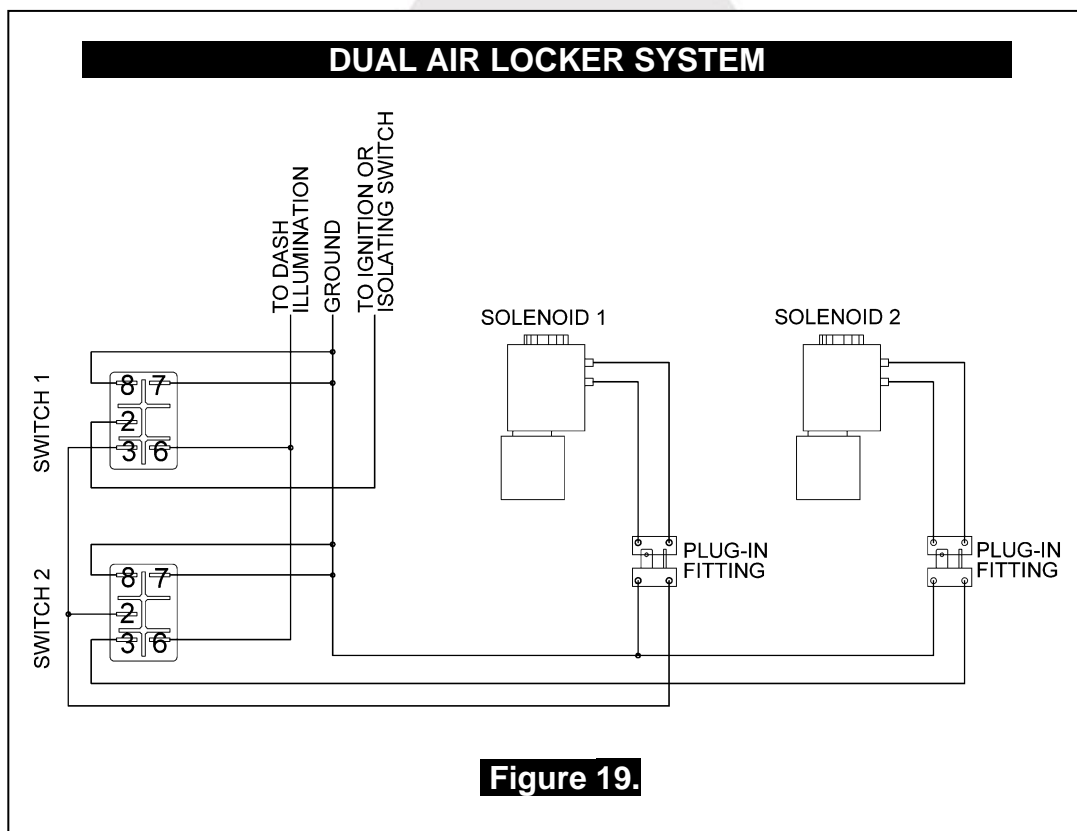

6 Testing & Final Assembly

6.1 Leak Testing

- With the vehicle parked and the engine off, turn the compressor on and wait until the air system is fully charged.

NOTE : With the *Air Locker(s)* disengaged, the air source (i.e., compressor) should not have to recharge over time. Intermittent recharging without *Air Locker* use usually indicates a leak at the solenoid fittings or at the compressor tank O-ring seal.

- Actuate the *Air Locker(s)*.
- The compressor should not come on again for a period of at least 15min. Air system recharging within that time period would indicate that a leak is present in the system.

NOTE : If an alternate air source (e.g., an air cylinder or a belt driven air pump) is used instead of a compressor, the air system will have to be leak tested with a pressure gauge and a shut-off valve in series before the solenoid input.

- If a leak is found to be present, spray a soap and water mixture onto all air fittings in the system while the compressor is fully charged. Bubbles should appear at any leak points.
- Check that leaky fittings have been adequately tightened.
- Disassemble, clean threads, and reapply thread sealant if leaking persists.

6.2 Testing the Air Locker Actuation

To test that your air system, electrical system, and your *Air Locker* differential is functioning correctly:

- Support the vehicle such that the wheels are free to rotate (e.g., on axle stands, a chassis hoist, etc.)
- Leave the parking brake off, the transmission in neutral, and the *Air Locker* switch 'OFF'.

6 Testing & Final Assembly

- Turn the ignition to the 'ON' position (leaving the motor off). The large illuminating symbol on the *Air Locker* switch cover should be 'OFF'.
- Turn the compressor (or alternate air source) on to charge the air supply up to its maximum pressure.
- Rotate one wheel by hand.
- The wheel should rotate freely and the opposite wheel should be turning in the opposite direction without any resistance or mechanical noise from within the differential.
- Turn the *Air Locker* switch to the 'ON' position. The illuminated symbol on the switch cover should light up.
- Rotate the same wheel again.
- Both wheels should rotate together.
- Turn the switch off again.
- Rotate the same wheel.
- The wheels should again rotate in opposite directions.

6.3 Re-Sealing & Filling the Differential

NOTE : Consult the *ARB Air Locker Operating & Service Manual* for recommendations on differential lubricant specifications.

- Replace the differential cover using gasket sealant or a standard differential cover gasket for your make of vehicle.
- Refill the differential until level with the filler hole.
- Rotate the differential center 2 full turns.
- Check the oil level and refill if necessary.
- Replace filler plug (apply thread sealant to filler plug before inserting if it is a threaded type plug).
- Wipe differential housing clean of any oil or grease which may collect dirt or other abrasive particles.

6 Testing & Final Assembly

6.4 Post-Installation Check List

Now that the *Air Locker* installation has been completed, ARB recommends that you take the time to complete the following check list just to insure that you haven't missed any of the vital steps.

- The air system has been leak tested.
- Thread locking compound was used on the ring gear bolts.
- All torque settings comply with the vehicle manufacturer's specs and were set with an accurate torque wrench.
- Differential fluid complies with ARB recommendations and has been filled to the correct level.
- All air lines and wiring have been securely cable tied to resist snagging.
- Switch(es) have been securely mounted within operator reach, yet well away from danger of accidental engagement.
- Switch(es) function correctly and illuminate to indicate that *Air Locker(s)* have been engaged.
- The *Air Locker* Warning Sticker has been located within close proximity of the actuator switch(es).
- All operators who are to use the *Air Locker* have read, and fully understand the *ARB Air Locker Operating & Service Manual*.

INSTALLATION PERFORMED BY: _____

DATE OF INSTALLATION: _____

ODOMETER READING: _____

AIR LOCKER SERIAL No.: _____





7 Parts List

RD93

Chrysler 8.25",29 SPL

7.1 Exploded Assembly Diagram (see itemized parts list overleaf)

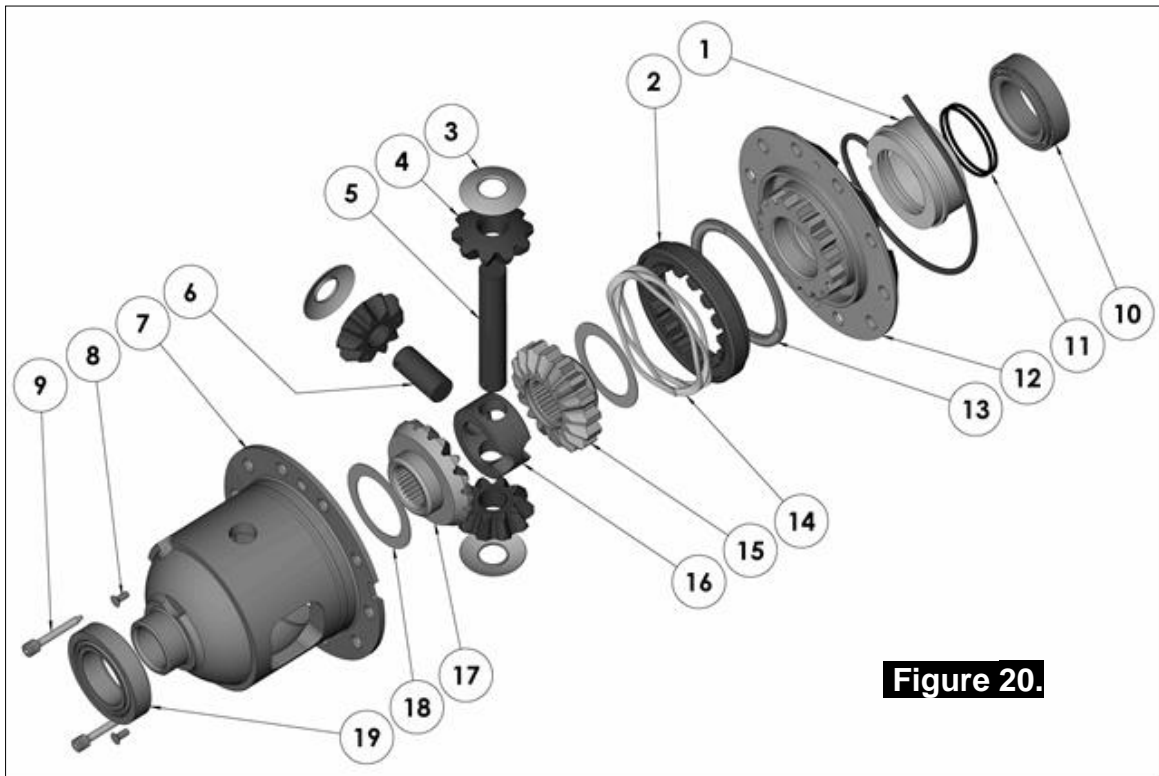

Figure 20.

7.2 Specifications

Axle Spline	29 tooth, Ø30.7mm [1.21"]
Ratio Supported	All
Ring Gear ID	130.5mm [5.14"]
Ring Gear OD	210mm [8.25"]
Ring Gear Bolts	10 bolts on Ø153 mm [6.00"]
Ring Gear Torque	76Nm [55 ft-lb]
Backlash	0.15-0.25mm [0.006-0.010"]
Bearing Cap Torque	81Nm [60 ft-lb]

7 Parts List

7.2 Itemized Parts List

(see exploded diagram Fig. 20.)

ITEM #	QTY	DESCRIPTION	PART #	NOTES
1	1	SEAL HOUSING KIT	081501SP	
2	1	CLUTCH GEAR & WAVESPRING KIT	050901SP	
3	3	PINION THRUST WASHER	SEE NOTE	4
4	3	PINION GEAR	SEE NOTE	3
5	1	LONG CROSS SHAFT	060204SP	
6	1	SHORT CROSS SHAFT	060403SP	
7	1	DIFFERENTIAL CASE	013002SP	
8	1	COUNTERSUNK SCREW (PK OF 2)	200213SP	
9	1	RETAINING PIN SET (PK OF 4)	120601SP	
10	1	TAPERED ROLLER BEARING	160109	2
11	1	SEAL HOUSING O-RINGS (PK OF 2)	160227-2	1
12	1	FLANGE CAP KIT	028402SP	
13	1	BONDED SEAL	160702	
14	1	WAVESPRING	150701SP	
15	1	SPLINED SIDE GEAR	SEE NOTE	3
16	1	SPIDER BLOCK	070902SP	
17	1	SIDE GEAR	SEE NOTE	3
18	2	SIDE GEAR THRUST WASHER	SEE NOTE	4
19	1	TAPERED ROLLER BEARING	NOT SUPPLIED	
*	1	C-CLIP KIT	CCK005	
*	1	AIR LINE (6mm DIA X 6m LONG)	170314SP	5
*	1	BULKHEAD FITTING KIT (BANJO TYPE)	170114	5
*	1	SOLENOID VALVE (12V)	180103	
*	1	CABLE TIE (PK OF 25)	180305	
*	1	SWITCH RR LOCKER	180224	
*	1	OPERATING & SERVICE MANUAL	210200	
*	1	INSTALLATION GUIDE	210293	

* *Not illustrated in exploded view*

NOTES

- 1 For replacement O-rings use only BS138 Viton 75.
 - 2 For replacement bearing use Timken part # LM102949 / LM102910.
 - 3 Available only as complete 5 gear set #728H021C
 - 4 Available only as complete thrust washer kit #730H01
 - 5 All diffs produced before serial #17070001 came with 5mm air connection system.
For information contact ARB
- RD93 suits C-clip & non C-clip applications.
 - Suitable for use with ABS tone ring.
 - Ring gear bolts are 3/8" - 20 left-hand thread, and must be removed in a clockwise direction.
 - Seal housing comes pre-installed.
 - To service O-rings or bearing remove the seal housing assembly with a bearing puller.

Part No. 210293
Revision 26/10/2020
Copyright © 2015 by ARB Corporation Limited